



**Health Management
Injury Prevention
Training Service**



1



Successful Spirometry

Kelly Spencer

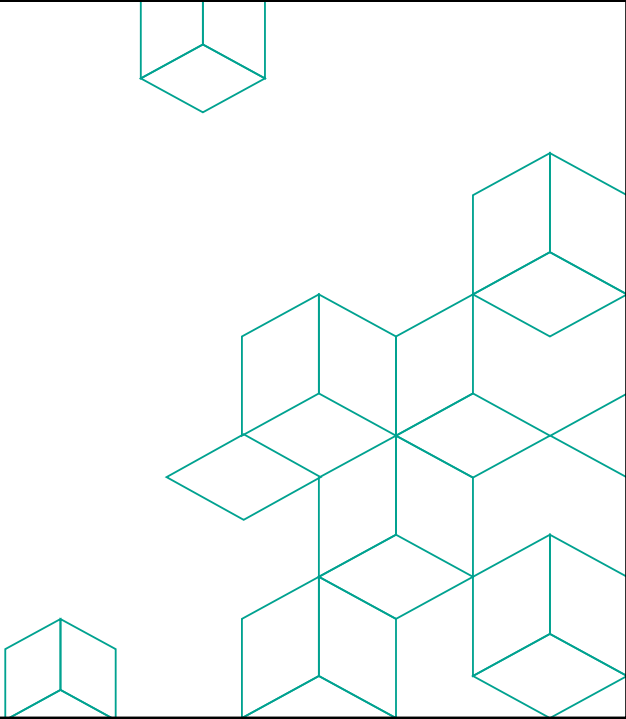

2



SKILL OF PERSON ADMINISTRATING THE TEST



ACTIVE AND MAXIMAL PATIENT PARTICIPATION

ACCURATE INSTRUCTIONS



3



“Spirometry is simple but when testing people even the simple is very difficult!”

Spirometry looks simple but the number of possible ways in which it can be performed incorrectly is immense

“Your breathing test results would be normal ... if you were 3'8" and 150 years old.”

CARTOONSTOCK.com

4

Overall aim is for you to acquire comprehensive knowledge of the application, measurement and interpretation of high-quality spirometry

- On completing the course, you should be able to:
- Identify the clinical indications for performance of spirometry and the limitations of spirometry
- Perform high quality spirometry
- Recognise poor quality spirometry
- Interpret spirometry in terms of the underlying lung physiology

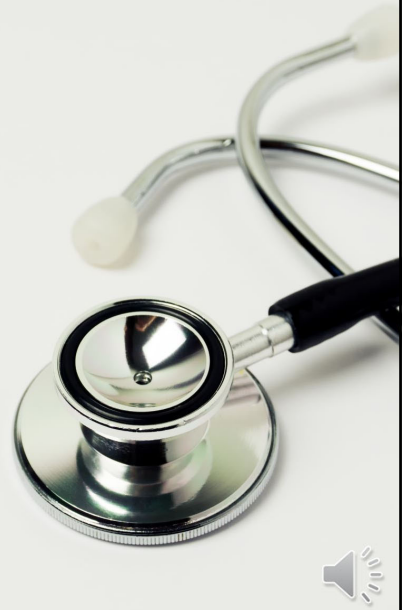

5

Objectives

- **Use spirometry as a tool to assist diagnosis and management**
- **Incorporate spirometry into routine clinical practice**
- **Use spirometric readings as a feedback tool for patient education**
- **Implement a quality assurance program for your spirometry**
- **Minimise cross-infection risks associated with the measurement of spirometry**



6

Final Report

- **Audit of spirometry equipment and training**
- **Quality assessment of 256 spirometry tests**
 - Less than 50% of spirometry currently performed is undertaken by sufficiently trained and experienced staff.
 - Overall, quality control and quality assurance of spirometry testing is inadequate for more than 50% of sites.



7

Spirometry Quality and Interpretation

- 40% DID NOT met ATS/ERS standards
- 100/256 reports reviewed accurately reported by NMA's
- Only 2 of the 30 abnormal where accurately identified



8



Recommendations

9



Spirometry
Logbook

Instructions

KINECT TRAINING
SPIROMETRY LOGBOOK
FROM / / 20 TO / / 20

Running Total	Date	Subject ID/Initial	3 acceptable trials	Were reported FEV1 and FVC repeatable	Comments
1					
2					
3					
4					
5					
6					
7					
8					
9					
10					
11					
12					
13					
14					
15					
16					
17					
18					
19					
20					
21					
22					
23					
24					

10

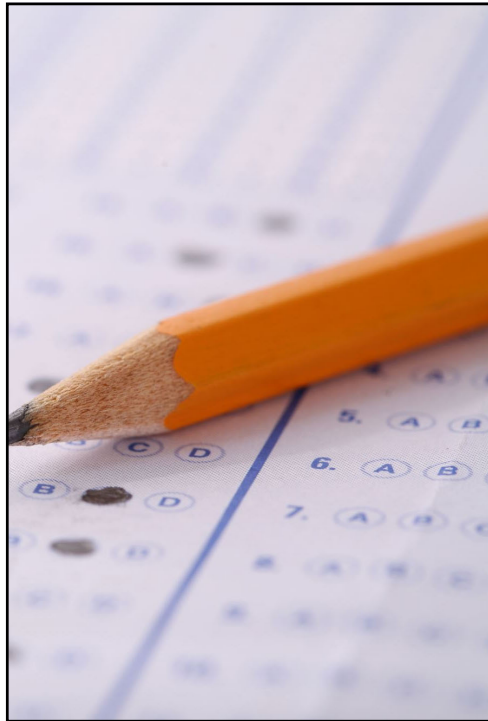

Introduction to Spirometry Overview

- **What and why of spirometry**
- **What is a spirometer**
 - Types of spirometer
- **Lung volumes/capacities – Activity 1- Workbook Activity**
- **Definitions and Graphs**
- **Contraindications and Test preparation**
- **Quality Assurance and Equipment maintenance**
- **Brainstorming- Why do calibrations fail – Activity 2**
- **Calibration Practical**



11

Testing during the Pandemic

- Use of disposable mouthpiece/sensor (easy on PC, Spiroscout) not recommended unless in line bacterial filters are in use
- Use of masks in waiting areas
- Maximize the use of single use consumables
- Use of PPE in high risk areas recommended – disposable gloves used at all times during testing
- Hand hygiene policy before and after use as per local policy
- Regular equipment cleaning protocols
- Adequate room ventilation



12

Bacterial Filters

- Optimal infection control for expiratory and inspiratory testing
- Provides 99.9% bacterial and viral efficiency
- Reduced risk of cross contamination for patients and health care professionals



13

Bluetooth



What is Spirometry?

- Most common test of Lung Function. Like BP for cardiovascular health
- Measures the flow and speed of air flow in and out the lungs.
- Reproducible and objective measurement
- Simple and inexpensive measurement which require
 1. accurate machine
 2. skilled operators
 3. cooperative subjects.
- Safe and relatively quick test to perform and with correct coaching **almost** all people can correctly perform the test



14



Diagnostic

To see if there is any ventilatory dysfunction or evaluate a known dysfunction.

To evaluate symptoms (chronic cough, SOB, sputum production).



Screening for early diagnosis in at risk populations (smokers/dust exposure).



Workplace/Pre employment assessments /Disability Evaluation

Assessment of risk for insurance valuation
Assessment for rehabilitation.

**What occupations do you think are at risk?
(pg.6 –workbook)**

Why Measure Spirometry?

15



Public Health

Clinical research.
Derivation of reference values.



Monitoring of Disease

To Measure the response to respiratory therapy.

To measure the response to drugs with potential pulmonary toxicity.



GOLD (Global Initiative for Chronic Obstructive Lung Disease) Guidelines – screening tool for the early detection of COPD in middle aged smokers.



GINA (Global Initiative for Asthma) Guidelines –measure of airflow limitation and its reversibility to establish a diagnosis of Asthma.

**What drugs do you know that are toxic to the lungs?
(Pg.6 Workbook)**

Why Measure Spirometry?

16

What is a Spirometer?

- A spirometer is an instrument used to measure respired volumes and flows.
- Many spirometers can measure both inspiratory and expiratory airflow.
- There are two general types of spirometers: volume-displacement and flow-sensing spirometers.
- The first spirometer was developed by London Surgeon John Hutchinson in the mid 1800's – it was a water sealed volume displacement device, he discovered that there was a linear relationship between height and Vital Capacity (VC) and a link between reduced Vital Capacity and Pulmonary Disease.

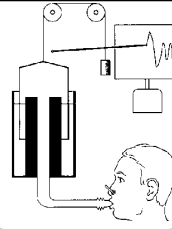

17



National
Asthma
Council



Spirometer
buyers' guide

Spirometer Buyers Guide

- List of Australian Distributors
- Comparison of Spirometer features
- GLI Availability
- Consumable cost

www.nationalasthma.org.au



18

Flow – sensing spirometers



The slide displays a large image of an EasyOne spirometer on the left. On the right, four smaller images illustrate different flow sensing technologies: Pneumotach, Ultrasound, Rotating Vane, and Mass flow sensor. A copyright notice for ©IARS 2016 is visible below the sensor images.

19

Spirometer – Easy on PC

- The *Easy on-PC* software is installed on a computer to which the *Easy on-PC* sensor is connected by means of a USB cable.
- The ultrasound flow sensor measures the transit time to determine flow velocity, volume and molar mass of the gas.
- Two ultrasound sensors emit very short ultrasound pulses that travel along the transmission path to the opposite ultrasound transducer.
- Since the measuring principle is based on a digital measurement technique, the sensor requires only one single calibration. The sensor calibration does not change during the sensor's lifetime.

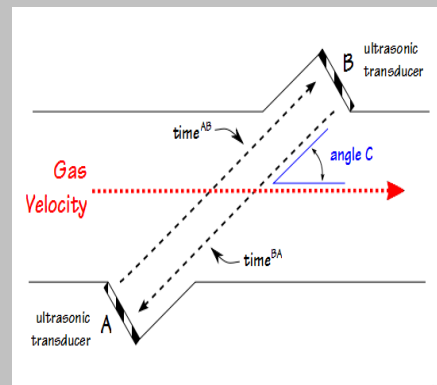

20

Accuracy and Quality of Spirometry in Primary Care Offices

[Matthew J. Hegewald^{1,2}](#), [Heather M. Gallo¹](#), and [Emily L. Wilson¹](#)

- Only 1 of 17 primary care spirometers tested met accuracy criteria.
- Although the accuracy errors were generally small, some errors of potential clinical significance were detected.
- Spirometer performance was notably lacking in the measurement of an obstructed waveform.
- Clinically acceptable spirograms were produced for only 60% of patients.
- These results raise concerns regarding the ability of primary care offices to obtain quality spirometry without greater attention to quality assurance and training.

<https://www.atsjournals.org/doi/full/10.1513/AnnalsATS.201605-418OC>



21

Spirometer performance



Volume

Capable of accumulating volume for 15 seconds
 Range: at least 8 L
 Accuracy: $\pm 3\%$ or ± 0.05 L, whichever is greater



Flow

Range: 0 – 14 L/sec
 Accuracy: $\pm 5\%$ of reading or ± 0.200 L/sec, whichever is greater



Display & printed reports

Aspect ratio: 2 units flow : 1 unit volume



22



Lung Volumes and Capacities Activity



23

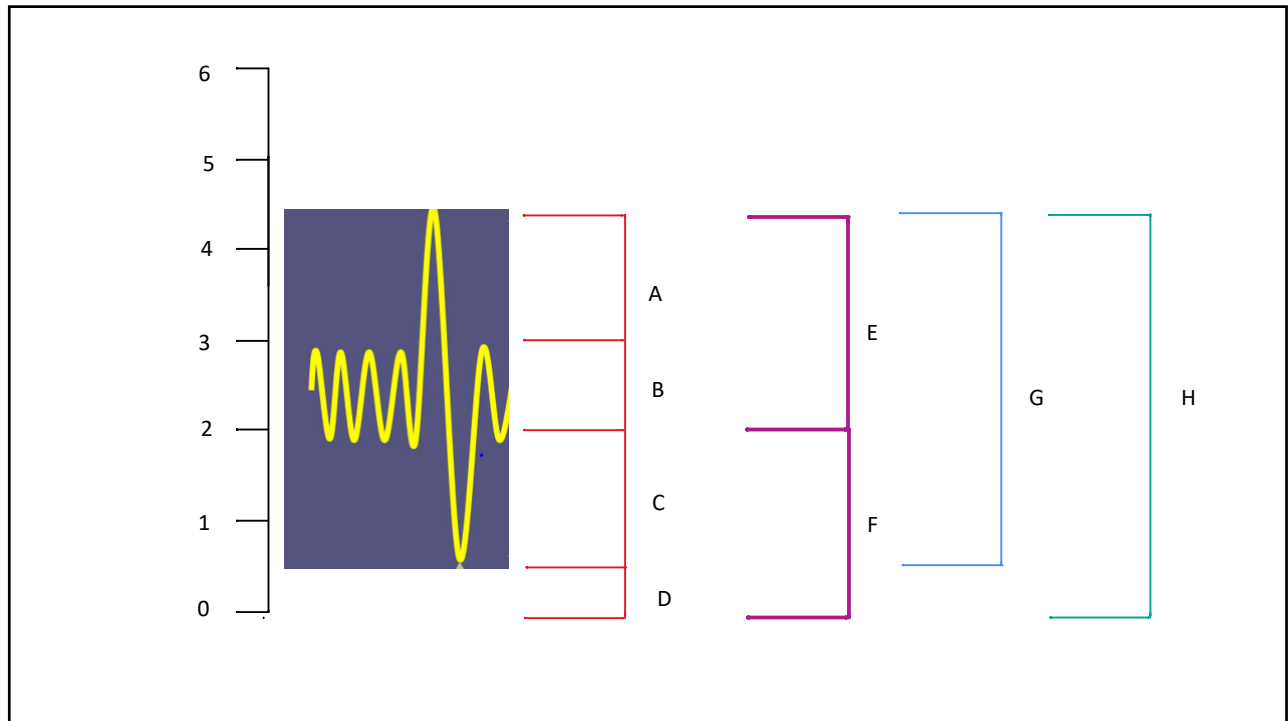

24

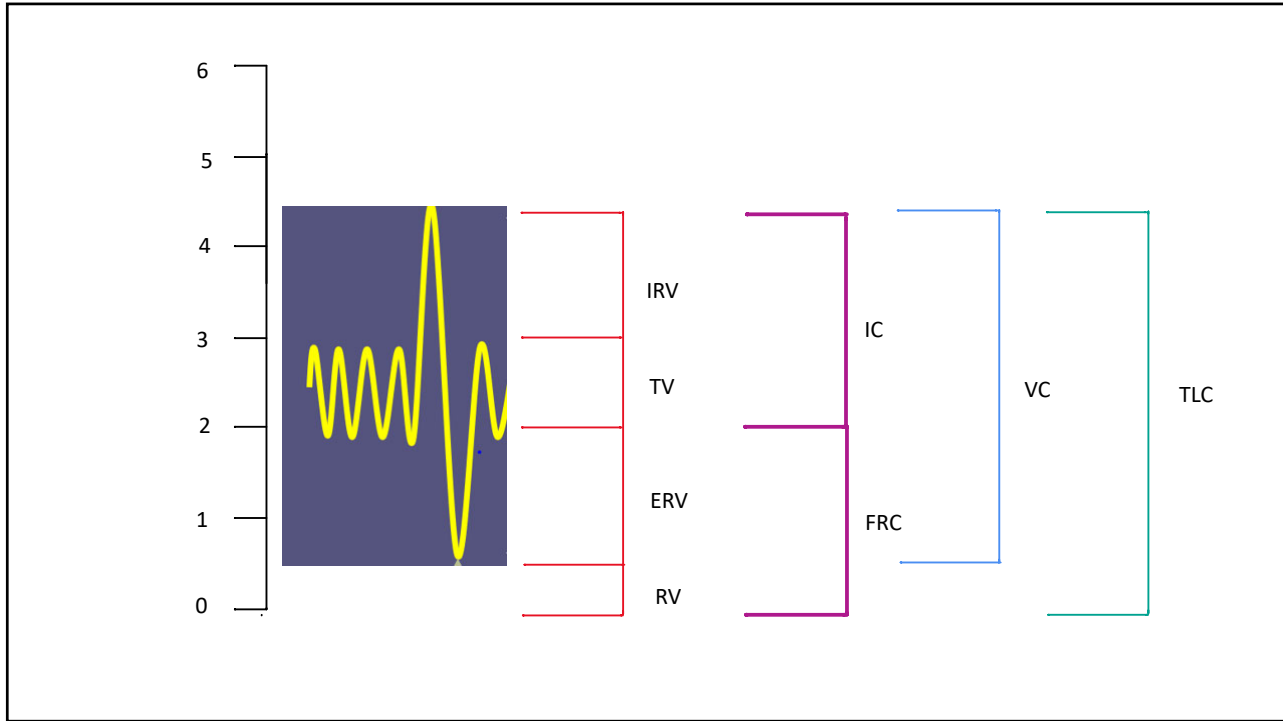

25

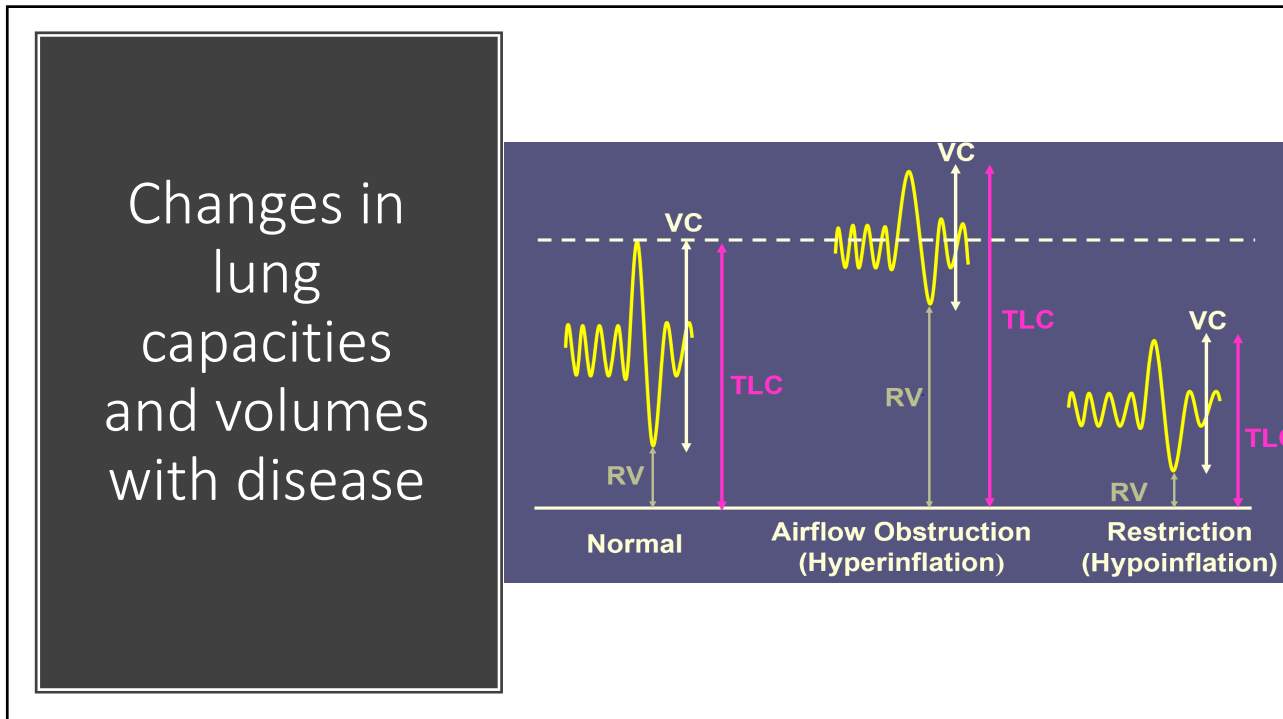

26

Body Plethsmography - Measuring FRC, RV,

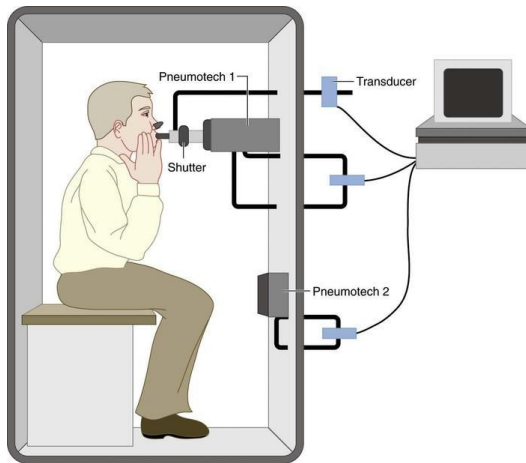

27

Measuring Tissue Damage in the Lungs

- Useful for diseases such as:-

- Asbestosis
- Silicosis
- COPD

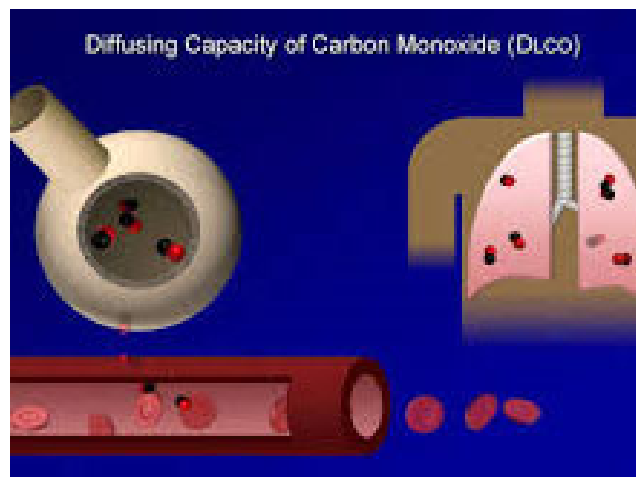

28

KINNECT TRAINING EST. 1996

Learning Outcomes

```
graph TD; A((Understanding of the governing bodies and standards for spirometry)) --> B((What is a spirometer)); B --> C((Why do we measure spirometry)); C --> D((Limitations of spirometry)); D --> E((Complementary lung function tests)); E --> A;
```

29

KINNECT TRAINING EST. 1996

Spirometry Definitions

30

Volume of expired in the first second of FVC

What is FEV1?

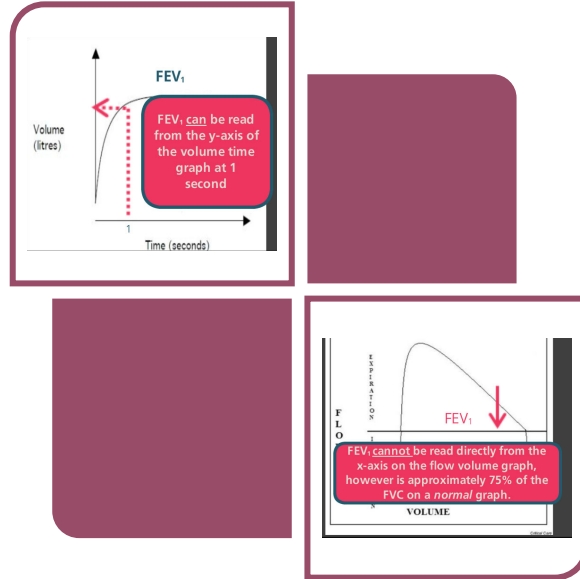

31

FVC is the total volume of air expired after a full inspiration

What is FVC?

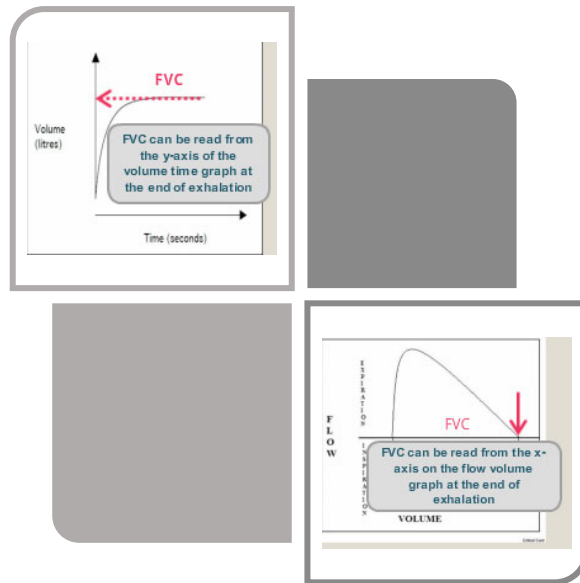

32

FEV₁/FVC Ratio

- This ratio is the FEV₁ expressed as a percentage of the FVC.
- In the Healthy Lung 75-85% of FVC is expired in one second.
- This ratio is a useful index of airflow limitation.

33

Other definitions

FET (forced expiratory time):

- Time required to perform the FVC manoeuvre

FEV₆ (forced expiratory volume in six seconds):

- Maximum volume of air that can be expired with maximally forced effort in six seconds

PEF (peak expiratory flow):

- Largest expiratory flow achieved during the forced expiratory manoeuvre initiated at full inspiration

34

Small Airways Disease (SAD)

- $FEF_{25-75\%}$
 - (forced expiratory flow between 25% and 75% of FVC):
- $FEF_{50\%}$
 - (forced expiratory flow at 50% of FVC):
- $FEF_{75\%}$
 - (forced expiratory flow at 75% of FVC)

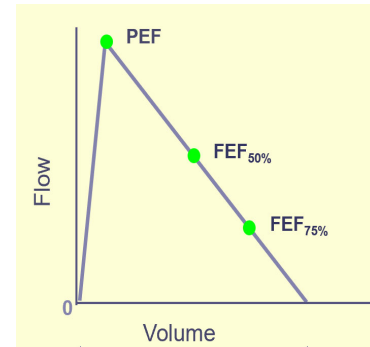

35

Why Use Both Graphs?

Volume-time curve is useful for assessing the latter stages of the manoeuvre

- Easier to see time of exhalation

Flow-volume curve can be used in the assessment of the first part of the manoeuvre

- Identify client technique

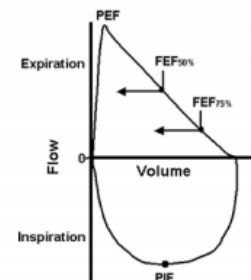
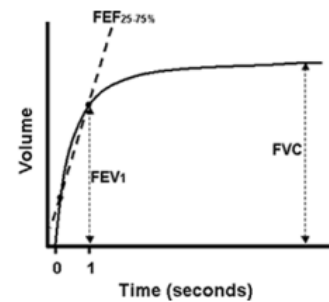

36

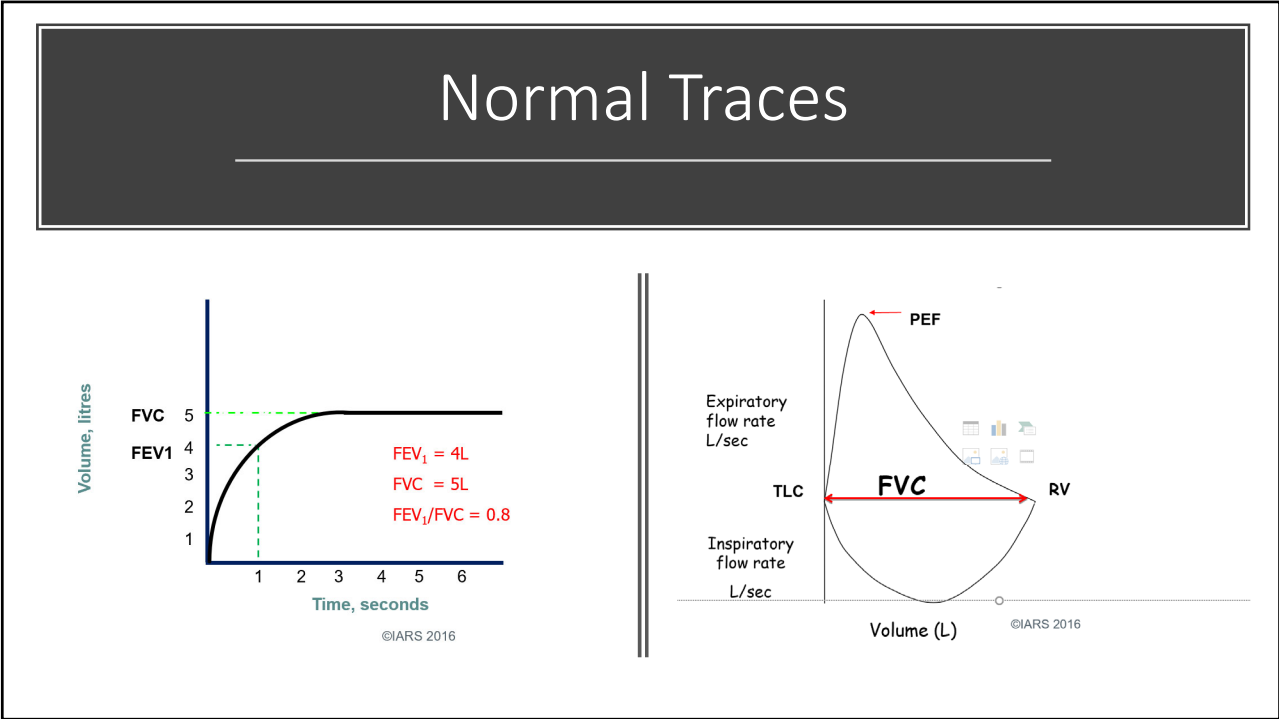

37

KINNECT TRAINING EST. 1996

Contraindications and Test Preparation

The slide features a logo for 'KINNECT TRAINING' with 'EST. 1996' in small text above it. Below the logo is the title 'Contraindications and Test Preparation'. The right side of the slide is decorated with a pattern of teal-outlined 3D cubes of varying sizes and orientations.

38

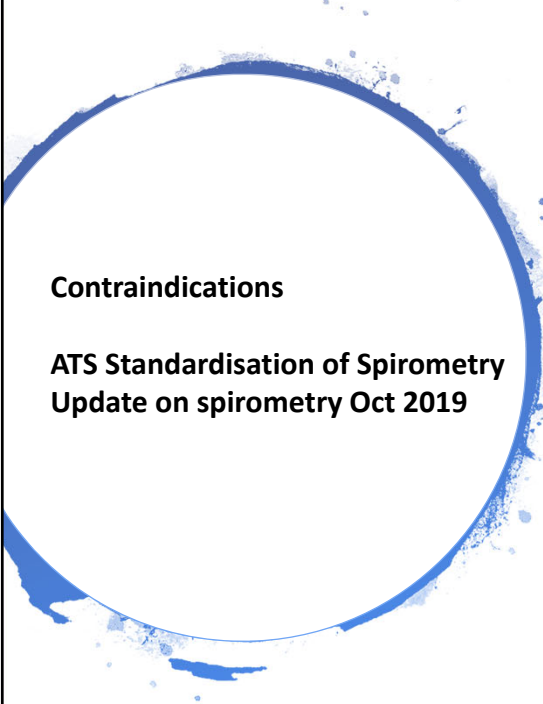

Contraindications

**ATS Standardisation of Spirometry
Update on spirometry Oct 2019**

Table 2. Relative Contraindications for Spirometry

Due to increases in myocardial demand or changes in blood pressure

- Acute myocardial infarction within 1 wk
- Systemic hypotension or severe hypertension
- Significant atrial/ventricular arrhythmia
- Noncompensated heart failure
- Uncontrolled pulmonary hypertension
- Acute cor pulmonale
- Clinically unstable pulmonary embolism
- History of syncope related to forced expiration/cough

Due to increases in intracranial/intraocular pressure

- Cerebral aneurysm
- Brain surgery within 4 wk
- Recent concussion with continuing symptoms
- Eye surgery within 1 wk

Due to increases in sinus and middle ear pressures

- Sinus surgery or middle ear surgery or infection within 1 wk

Due to increases in intrathoracic and intraabdominal pressure

- Presence of pneumothorax
- Thoracic surgery within 4 wk
- Abdominal surgery within 4 wk
- Late-term pregnancy

Infection control issues

- Active or suspected transmissible respiratory or systemic infection, including tuberculosis
- Physical conditions predisposing to transmission of infections, such as hemoptysis, significant secretions, or oral lesions or oral bleeding

39

Preparation for Spirometry

Handwashing	?Bronchodilator medications have been taken.	Smoking/ vaping/ water pipe 1 hour prior	no intoxicants 8 hours prior
no vigorous exercise 1 hour prior	Ensure client is wearing loose comfortable clothing.	Obtain relevant history <ul style="list-style-type: none"> • medical history • smoking history • work/occupational exposure history 	Obtain clients ethnic origin

40

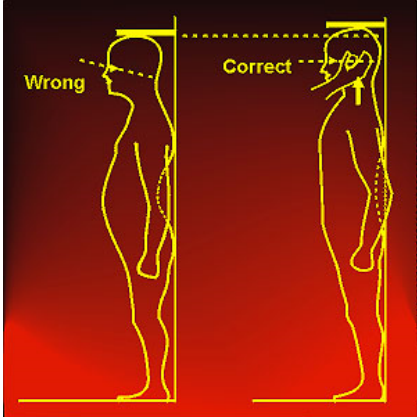

Do

- ✓ stand straight with heels together without shoes
- ✓ actively stretch to a fully erect position
- ✓ look straight ahead
- ✓ compress the hair as much as possible with the horizontal arm remaining at 90°
- ✓ Height should be recorded to the closest mm

Don't

- ☒ Self-reported height
- ☒ Shoes on
- ☒ Hair accessories not removed
- ☒ Equipment not properly installed
- ☒ Knees bent
- ☒ Head out of position

©IARS 2016

Patient Preparation...Standing Height

Standing height is an important predictor of lung function indices

41

Measuring height accurately



42

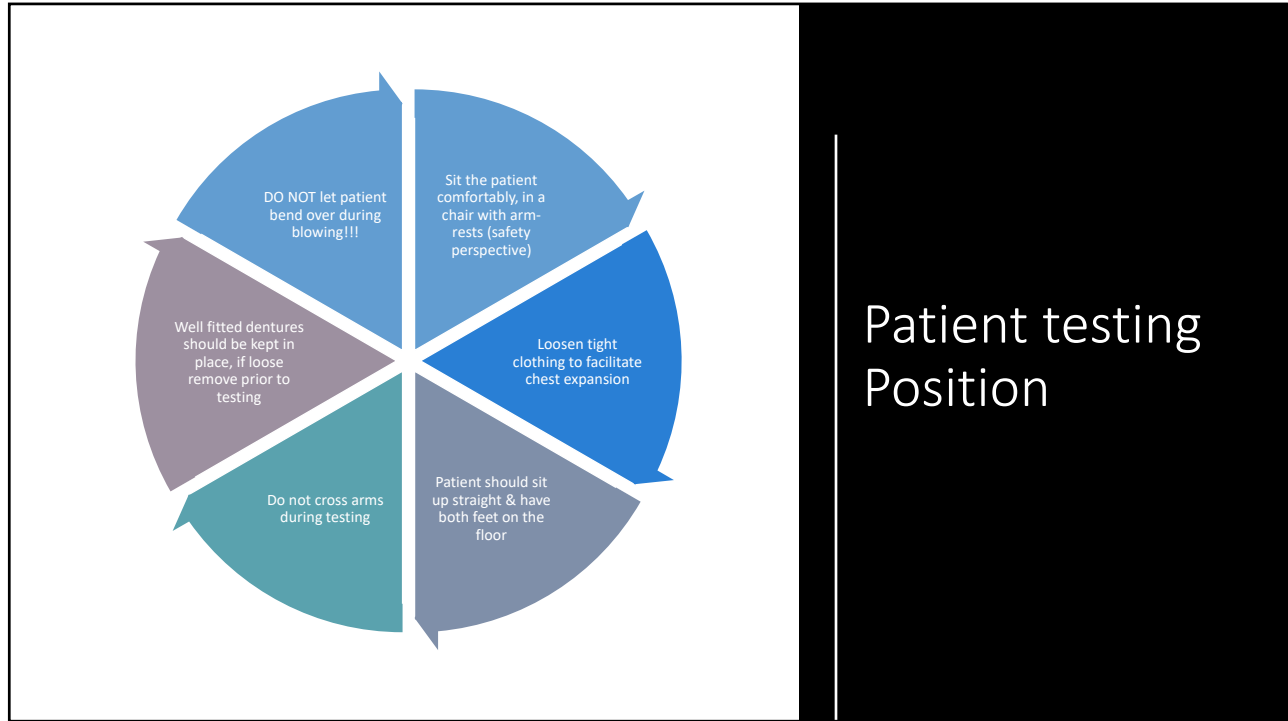

Patient testing Position

43

Withholding medications

(Pg.14 – Workbook)
Available in online resources

Relievers	Maintenance			
<p>SABA: Short-acting beta₂-agonists</p> <p>4 hours</p> <p>Venlo[®] Autohaler[®]</p> <p>Aero[®] MDI</p> <p>Aero[®] Autohaler[®]</p> <p>Bicary[®] Turbohaler[®]</p> <p>SAMA: Short-acting muscarinic antagonist</p> <p>4 hours</p> <p>Abravon[®] MDI</p>	<p>LAMA: Long-acting muscarinic antagonists</p> <p>24 hours</p> <p>Spiriva[®] Handihaler[®]</p> <p>Incruse[®] Ellipta[®]</p> <p>Breathal[®]</p> <p>Tealir[®] Breathal[®]</p> <p>ICS/LABA combinations</p> <p>Breathal[®] Genual[®]</p> <p>Symbicort[®] Rophalar[®]</p> <p>Seretide[®] Accuhaler[®]</p> <p>Seretide[®] MDI</p> <p>SAMA: Short-acting muscarinic antagonist</p> <p>12 hours</p> <p>Breo[®] Ellipta[®]</p> <p>Fluticasone + Salmeterol Cgla[®] Salplus[®] MDI</p> <p>ICS/LAMA/ABA combination</p> <p>24 hours</p> <p>Treligy[®] Ellipta[®]</p>	<p>LAMA/ABA combinations</p> <p>24 hours</p> <p>Utibyo[®] Breathal[®]</p> <p>Ancor[®] Ellipta[®]</p> <p>ICS/LABA combinations</p> <p>Symbicort[®] Turbohaler[®]</p> <p>DuoResp[®] Spiromax[®]</p>	<p>LABA: Long-acting beta₂-agonists</p> <p>12 hours</p> <p>Onbrez[®] Breathal[®]</p> <p>*Oxis[®] Turbohaler[®]</p> <p>*Serevent[®] Accuhaler[®]</p> <p>ICS: Inhaled corticosteroids (For patients with COPD and Asthma)</p> <p>No need to withhold</p> <p>*Flutide[®] MDI</p> <p>*Fluonid[®] Accuhaler[®]</p> <p>*Flutiform[®] MDI</p> <p>ICS/LABA combination</p> <p>12 hours</p> <p>*Flutiform[®] MDI</p>	
				<p>My local support</p> <p>Pulmonary rehabilitation program <input type="text"/></p> <p>Lungs in Action class <input type="text"/></p> <p>Support Group <input type="text"/></p>

44

Test performance

Open circuit method

- Inhale completely and **rapidly**
- Pause <1 sec
- Seal lips around the mouthpiece
- Blast air out as fast and as far as possible until completely empty, or until unable to blow any longer

45

Test performance *cont.*

Closed circuit method

- Seal lips around the mouthpiece
- Inhale completely and **rapidly**
- Pause <1 sec
- Blast air out as fast and as far as possible until completely empty, or until unable to blow any longer
- To complete loop finish with a full breath in back to TLC. Lips can be removed from the mouthpiece at this point

Now recommended as best practice in ATS 2019 Standards for spirometry

46

Test Procedure

Explain and demonstrate	Activate	Instruct	Instruct	Observe	Terminate	Terminate
<ul style="list-style-type: none"> Explain and demonstrate the correct procedure. 	<ul style="list-style-type: none"> Activate Spirometer & block spirette (this is necessary to set the baseline correctly) 	<ul style="list-style-type: none"> Instruct client to inhale completely and rapidly until their lungs are full, place mouthpiece in mouth and close lips tightly around the mouthpiece while holding their lungs full. 	<ul style="list-style-type: none"> Instruct client to exhale forcefully until no more air can be expelled 	<ul style="list-style-type: none"> Observe client in case they become unsteady due to light-headedness or experience other adverse reactions such as chest pain. 	<ul style="list-style-type: none"> Terminate trial once the end of test criteria have been met. Repeat a minimum of 3 times, coaching client as required, up to a maximum of 8 trials. 	<ul style="list-style-type: none"> Terminate test once the acceptability and repeatability criteria have been met and record Results – the largest value for the FVC and FEV1

47

Phase 1: Maximal Inspiration (pg.77 ATS, 2019)



A sub maximal inspiration will cause all subsequent spirometry values

TO BE UNDERESTIMATED!!

Sternocleidomastoideus

scalenis

48

Phase 2 – Rapid Forced Expiration

Instruction

'Blast' as hard and as fast as you can'

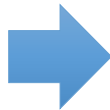

Without a 'blast' the FEV1 and PEF will be underestimated.

Look for

- Fast rise to peak flow
- No cough in first second
- No hesitation, slow start
- No obstruction at the Mouthpiece (dentures/tongue)

©IARS 2016

49

Phase 3 – Continued Forced Expiration

Instruction

'keep going, keep going, keep going....forcing all the air out'

**Failure to do so leads to :
Underestimation of FVC and
overestimation of FEV1/FVC ratio**

Look for

- Smooth uninterrupted expiration
- Maximal effort on entire manoeuvre
- Expiration time ≥ 6 s with >1 sec plateau in V-T

©IARS 2016

50

Phase 4 – Full Flow Volume Loop – Inhalation back to TLC

2019 Guidelines state:

- The 2019 Spirometry Standard requires that FIVC be reported. (page e82, table 9).
- The 2019 Standards mandates that the flow-volume loop is an integral part of spirometry. (page e82, column 3, paragraph 2)

FIVC – FVC must be <100ml or 5% of FVC whichever is greater

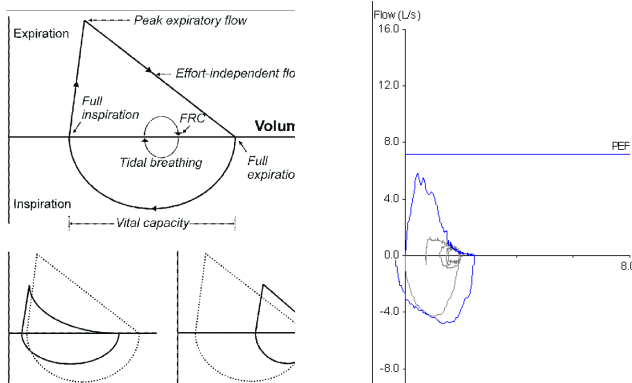

51



52



Quality Assurance, Biological Controls and Reference Values

53

Measuring Ambient Conditions

- Weather station in room
 - Close to spirometer
- Temperature
 - If room temp changes by 2 degrees – recalibrate
- Barometric Pressure and humidity (760 mmHg and approx. 50%)
- <http://www.bom.gov.au/qld/observations/qldall.shtml>
- (1.3322387415 hPa = 1mmHg)

54

Correcting for Body Temperature, Pressure, Saturated (Water Vapour)

Warm moist air from the lungs at 37°C & BTPS enters the cooler spirometer at 21°C, the gas molecules shrink and the volume is reduced.

Changes in spirometer temperature can be a source of variability.

Spirometer must be at adequate temperature (Car boot to Room, Spirometer in direct sunlight)

17-40°C is usual range allowed

Desktop spirometers usually have internal thermometers but these could become faulty - be aware!

! Think about having an external weather station

55

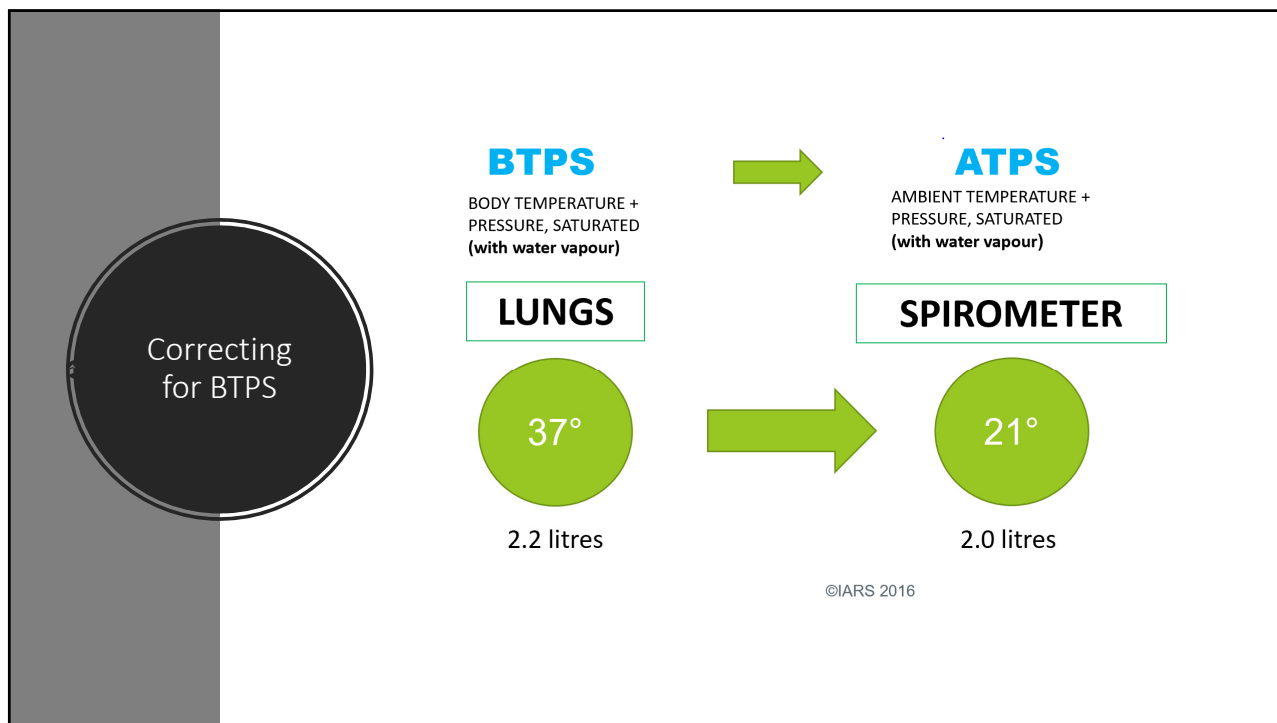

Spirometer Quality Control

- Instrument Maintenance
- Instrument Calibration (Calibration syringe)-
Daily
- Linearity Check – **Monthly** (weekly if poss)
 - After repairs
 - After maintenance
 - After Software changes
- Biological Control testing- Monthly
 - After repairs
 - After maintenance
 - After Software changes

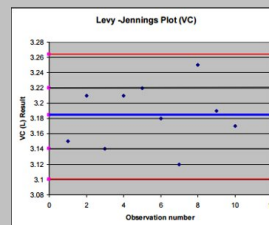

57

Calibration

- Frequency
 - Depends on type of spirometer, its stability, change in room temp
 - ATS/ERS recommend **daily validation**
 - 3-litre calibration syringe
 - Empty the syringe at different speeds
- 3 litres should record between
2.895 - 3.105 L (ATPS) (3.5%) **updated to 3% in 2019 guidelines**
(2.91-3.09)
- 3% spirometer error (**2.5% spirometer error**)
 - 0.5% syringe error
- Timing accuracy (quarterly)
 - Store syringe in same room as spirometer



58

Syringe Checks

Syringe re-validation: re-validated on a yearly basis or as specified by the manufacturer.

Syringe leak test: Tested for leaks and smoothness of operation minimally on a weekly basis.

- The syringe should be tested from a full (drawn back) position by placing a hand over the outlet and depressing the syringe handle gently. No air should escape. Secondly the syringe should be emptied, and in an empty position should be checked by again placing a hand over the outlet, then pulling gently on the syringe handle. No air should enter the syringe. Syringes that leak may not measure proper volume and should be sent for service.

Syringe smoothness test: Move the syringe handle back and forth to check that the action is smooth, without catching or stuttering. Syringes that do not move smoothly may not deliver proper volume and should be sent for service.

59

Linearity Check

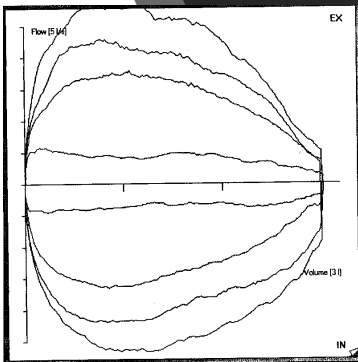

- The syringe should be injected and/or withdrawn at least 3 times, at varying flows
 - $< 2\text{L/s}$
 - $4\text{L/s} - 6\text{L/s}$
 - $> 8\text{L/s}$
- Linearity Testing - Set up a mock patient study.
- Enter the patient data as follows:
 - First Name: QC
 - Last Name: Syringe
 - Weight: 150 lbs. (or 68 kg)
 - Height: 64 in. (or 163 cm)
 - Age: 40

60

Acceptable results at ambient temperature (Accuracy verification)

A. Acceptable results at ambient temperature (accuracy verification):

Spirometers may measure volume at body temperature (BTPS) or at ambient/room temperature (ATPS). Most spirometers in physicians' offices will report at BTPS. Spirometers reporting at BTPS automatically employ correction factors, at specific temperatures, that convert ATPS to BTPS. Here is an example for an ambient temperature of 21°C:

- Volume of 3-L syringe = 3.00 L
- Correction factor at 21°C = 1.096
- Therefore: 3.00 L x 1.096 = 3.28 L
- Acceptable accuracy is ± 3.5%. Therefore:
 - 3.28 L minus 3.5% = 3.17 L
 - 3.28 plus 3.5% = 3.40 L
- The acceptable range at 21°C is 3.17 L–3.40 L

The chart below has already calculated the acceptable ranges at each temperature for spirometers reporting at BTPS. In order to verify the accuracy of your measurement, use the chart to determine the FVC acceptable range for each trial, at your ambient temperature:

BTPS Chart for Acceptable Ranges (± 3.5%)

Factor	°C	Acceptable Range (L)	Factor	°C	Acceptable Range (L)	Factor	°C	Acceptable Range (L)
1.118	18	3.24 – 3.47	1.085	23	3.14 – 3.37	1.057	28	3.06 - 3.28
1.111	19	3.21 – 3.45	1.080	24	3.13 – 3.35	1.051	29	3.04 - 3.26
1.102	20	3.19 - 3.42	1.075	25	3.11 – 3.34	1.045	30	3.03 - 3.25
1.096	21	3.17 – 3.40	1.068	26	3.09 – 3.32			
1.091	22	3.16 – 3.39	1.063	27	3.08 - 3.30			

61

Establishing the BioQC Normal Range



- 1. Perform 10 to 20 replicates on each BioQC subject over a period of several days.
- Ideally this should entail a single test performed each day; however a maximum of 2 tests spread out within any single day (e.g. morning and afternoon) may be used.
- 2. Use the Normal Range Calculator to determine the acceptable ranges for each person. This worksheet takes the average of the replicates and calculates two standard deviations (SD) which constitutes the normal range for this subject.
 - The average, standard deviation (SD) and coefficient of variation (CV) will automatically be calculated.
 - There should be a maximum of 10% between the highest and lowest FVC and FEV1 values.
 - The calculated coefficient of variation (CV) should be 5% or less.
- 3. Subsequent spirometry testing on each BioQC subject should fall within the ± 2 SD ranges for that subject.
- 4. Perform troubleshooting if BioQC values fall outside of their acceptable ranges.

62

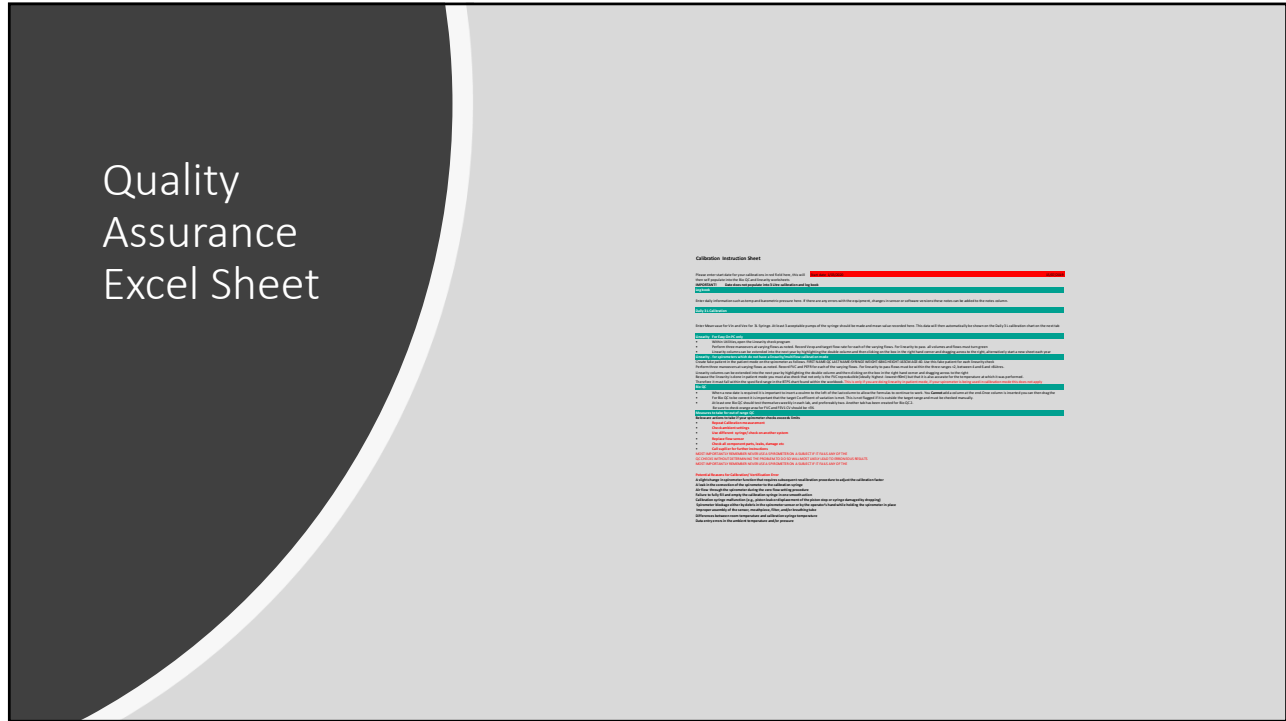

63

Equipment maintenance



Refer to your equipment manual for maintenance methods and schedule



Ongoing maintenance usually includes:

- Calibration (or validation of accuracy)
- Cleaning and disinfection procedures
- Electrical operation and safety checks
- Mechanical operation and safety checks
- Software/database maintenance and back-up



Keep records (logbook):

- Document servicing
- If new version of software is installed
- Problems as they occur
- Check stability of equipment

64

Brain Storming

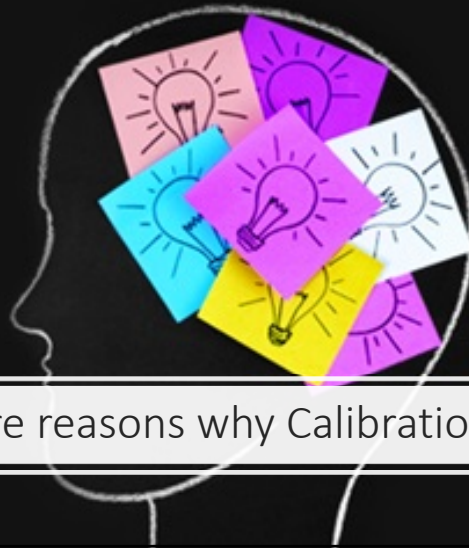

What are reasons why Calibrations might fail?

65

Potential Reasons for Calibration/ Verification Failure



- A slight change in spirometer function that requires subsequent recalibration procedure to adjust the calibration factor
- A leak in the connection of the spirometer to the calibration syringe
- Airflow through the spirometer during the zero-flow setting procedure
- Failure to fully fill and empty the calibration syringe in one smooth action
- Calibration syringe malfunction (e.g. piston leak or displacement of the piston stop, or syringe damaged by dropping)
- Spirometer blockage either by debris in the spirometer sensor or by the operator's hand whilst holding the spirometer in place
- Improper assembly of the sensor, mouthpiece, filter and/or breathing tube
- Differences between room temperature and calibration syringe temperature
- Data entry error in ambient temperature and/or pressure

66

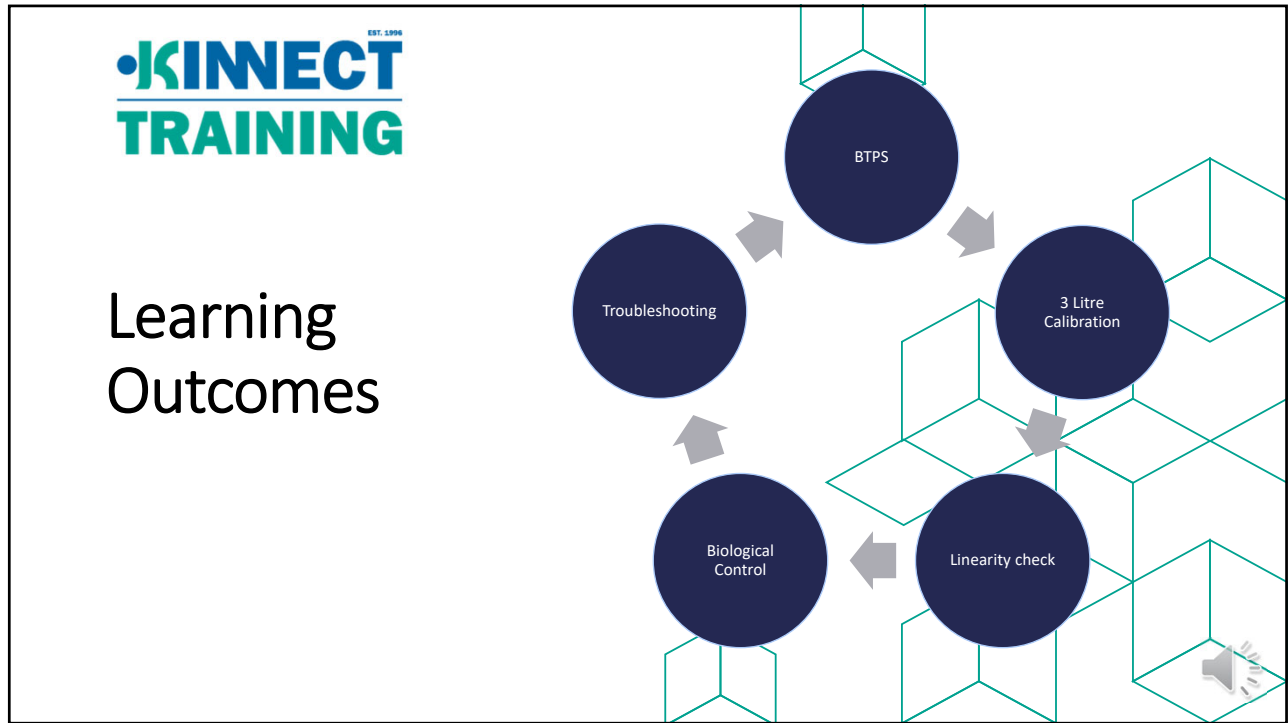

67



68

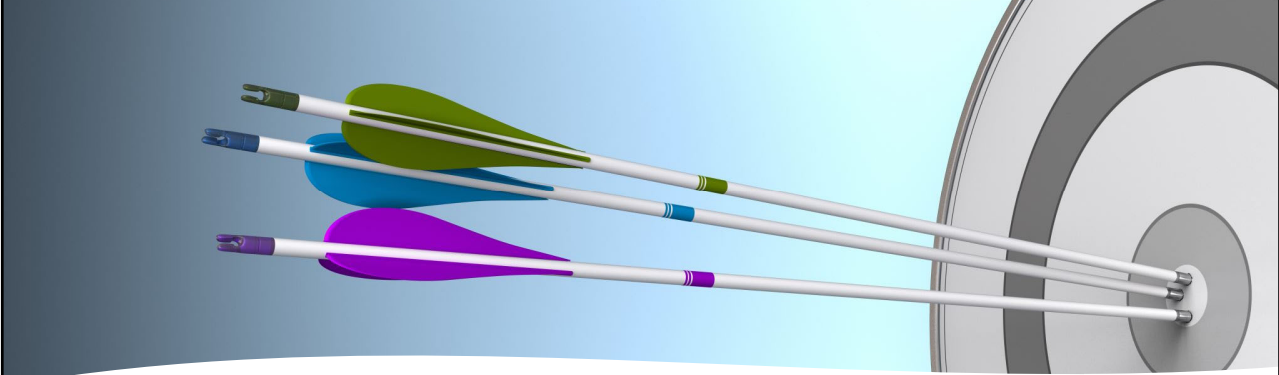

Part 2

Obtaining
Repeatable
Spirometry

69

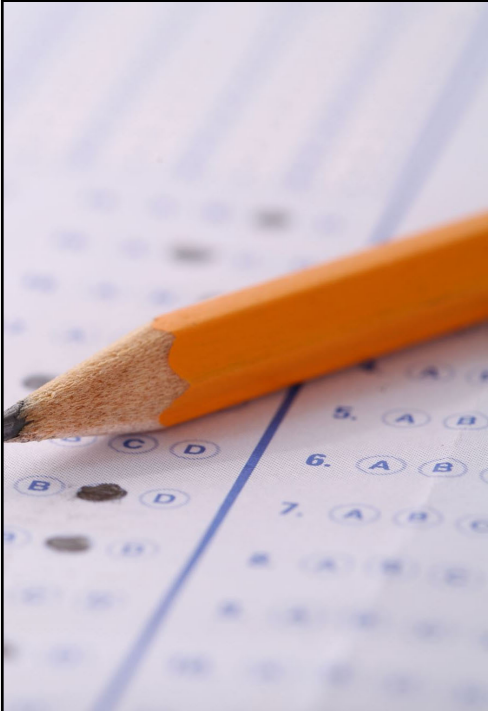

Spirometry Testing Overview

- Start of Test Criteria
- Middle of Test Criteria
- End of Test Criteria
- Repeatability
- Troubleshooting
- Spirometry Induced Bronchoconstriction
- Data Selection/ Grading
- **Demonstration of correct technique/ Practical session**
- Assessment/ calculation of reversibility
- Reference Values/ GLI



70



Start of test Criteria

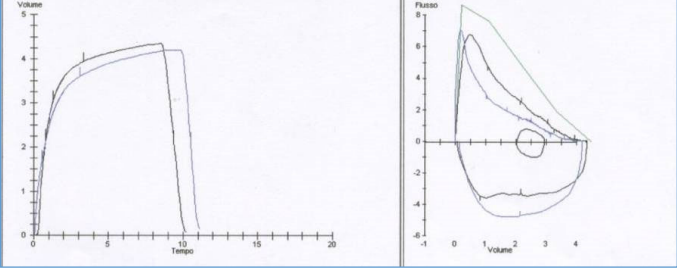

- Begins from full inspiration has a rapid start of test, If the manoeuvre has an obviously hesitant start then the trial should be terminated early to avoid unnecessary prolonged effort.
- Short rise time (less than 10msec)

71

Back Extrapolation

According to the ATS Guidelines, Extrapolated volume must be < 5% of FVC or 0.150L (reduced to 0.100 L in 2019 paper) whichever is greatest

Must have acceptable FVC to determine 5% threshold

Patient hesitates during expiration and consequently has a poor start to the blow.

FEV1 calculated as 2.5L

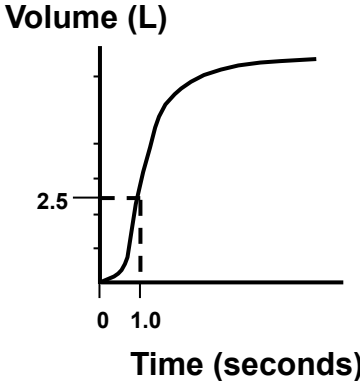

72

Effect of Back Extrapolation on Volume

A back extrapolation line is positioned on the straightest part of the curve, creating a new 'zero' point

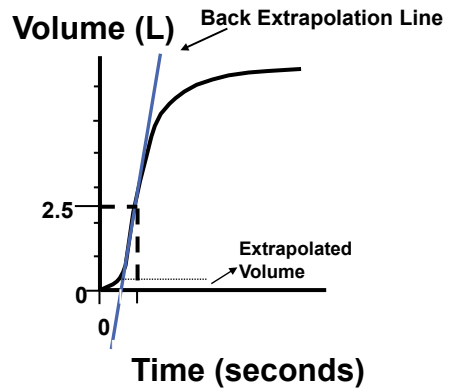

73

Effect of Back Extrapolation on Volume

With a new zero point the FEV1 is now re-calculated to be 5.0 L and NOT 2.5 L

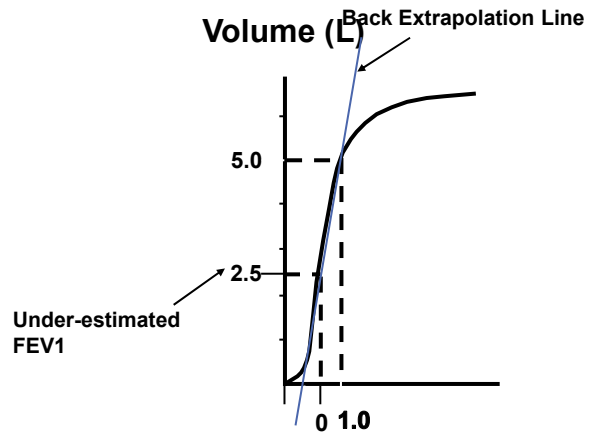

74



Middle of Test Criteria

- No obstruction, hesitation or artefact impeding the blow including:
 - Cough during the first second of exhalation
 - Glottic closure that influences the measurement
 - Early termination or cut-off
 - Effort that is not maximal throughout
 - Air leaks at mouth
 - Obstructed mouthpiece (due to tongue or teeth in front of the mouthpiece, or mouthpiece deformation due to biting).

75



End of Test Criteria

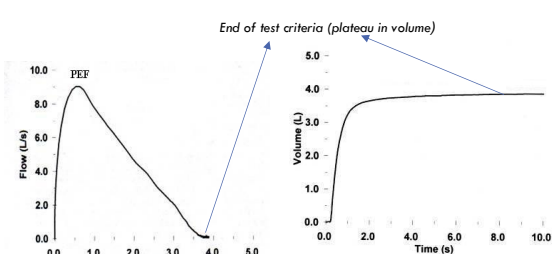

- The subject cannot or should not continue expiration **or**
- Minimum expiration time of 6 seconds, unless there is an obvious plateau of reasonable duration
- No manoeuvre should be eliminated solely because of early termination (< 6 secs).
- FEV1 may be valid and the volume expired may be an estimate of the true FVC although the FEV1/FVC % ratio may be overestimated.
- Note: This is the most frequent reason for unacceptable manoeuvres**

Miller et al. ERJ 05

76

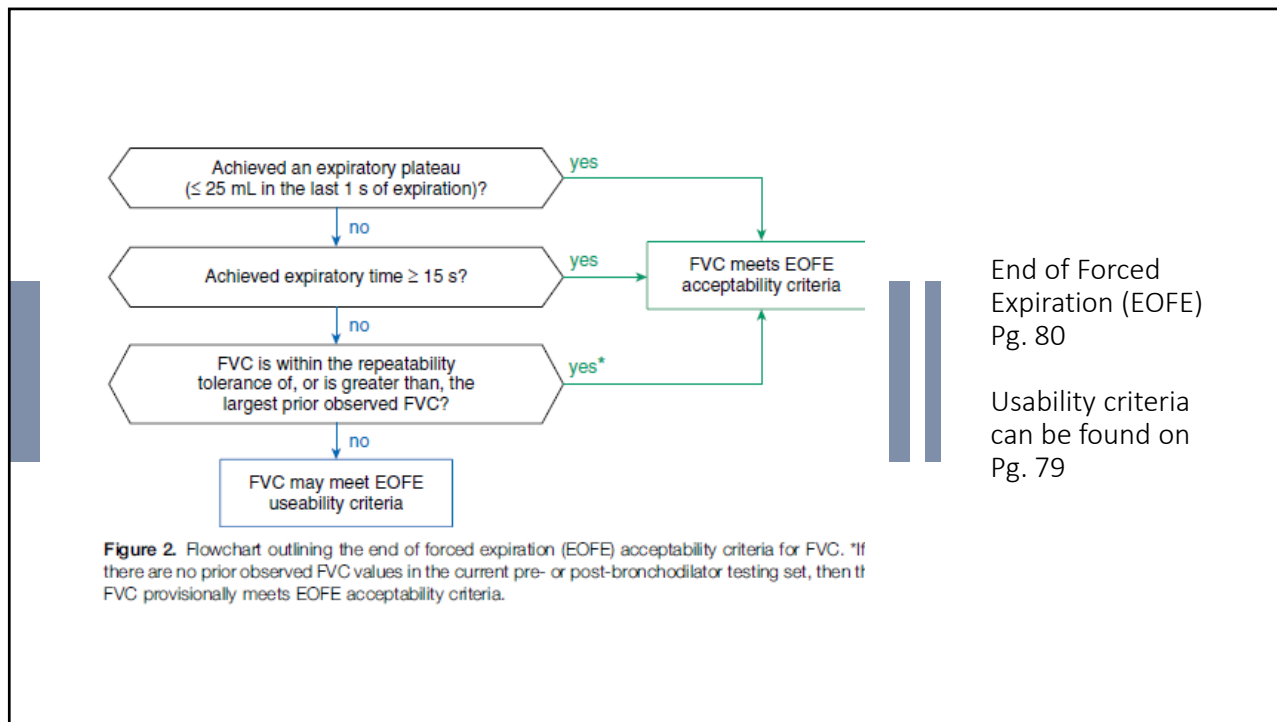

77

FVC is within repeatability tolerance of or is greater than the prior observed FVC

Occurs when the subject cannot expire long enough to achieve a plateau

- Children/young adults with high elastic recoil
- Patients with restrictive lung disease
- Or when a subject inspires or comes of the mouthpiece before plateau

For within manoeuvre acceptability, the FVC must be greater than or within the repeatability tolerance of the largest FVC observed before this manoeuvre with the current pre or post bronchodilator testing session

Because the minimum FET has been eliminated increased vigilance by the operator and the interpreter is required in the assessment of whether expiration was complete or there was early termination

78

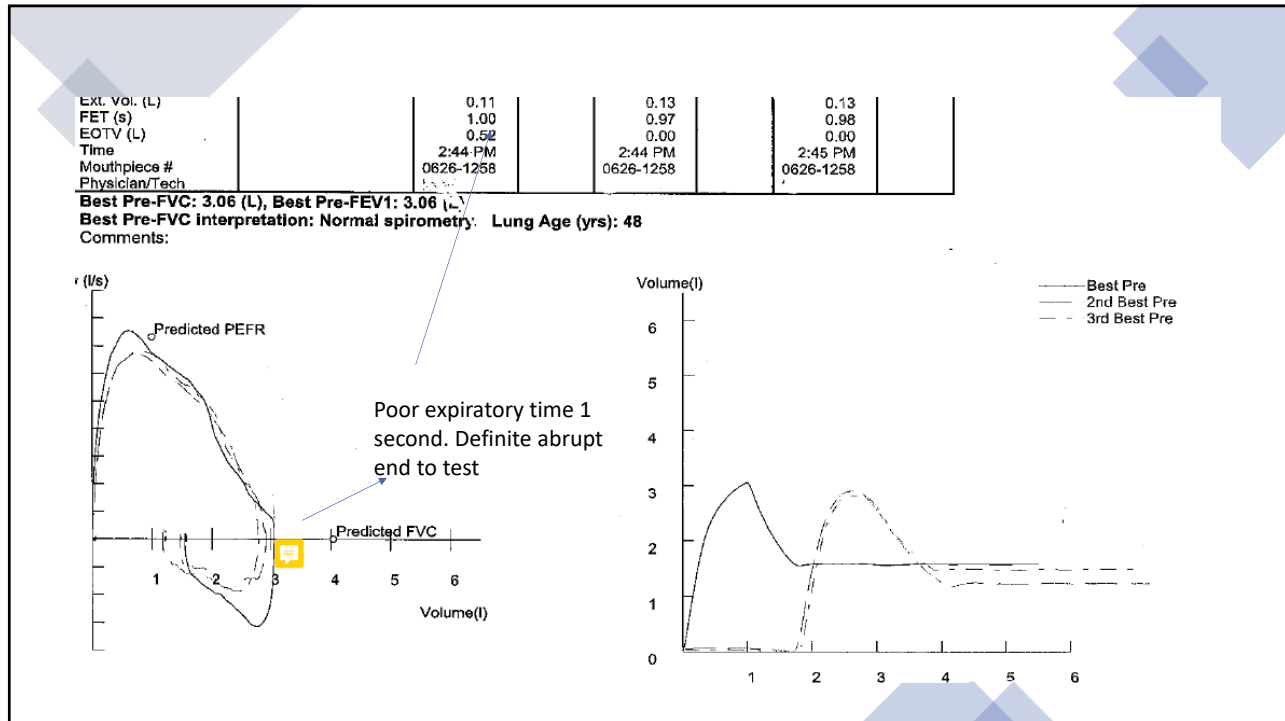

79



Repeatability Criteria

- After three acceptable spirometers have been obtained, the following checks are used to assess for repeatability:
- The two largest values of FVC or VC must be within **0.150L** of each other
- The two largest values of FEV1 must be within **0.150L** of each other
- For patients with an FVC or VC of $\leq 1.0L$ the two largest FVC or VC and FEV1 values must be within 0.100L of each other
- A minimum of three acceptable manoeuvres should be saved and utilised for analysis/interpretation.

80

How to calculate Repeatability Criteria

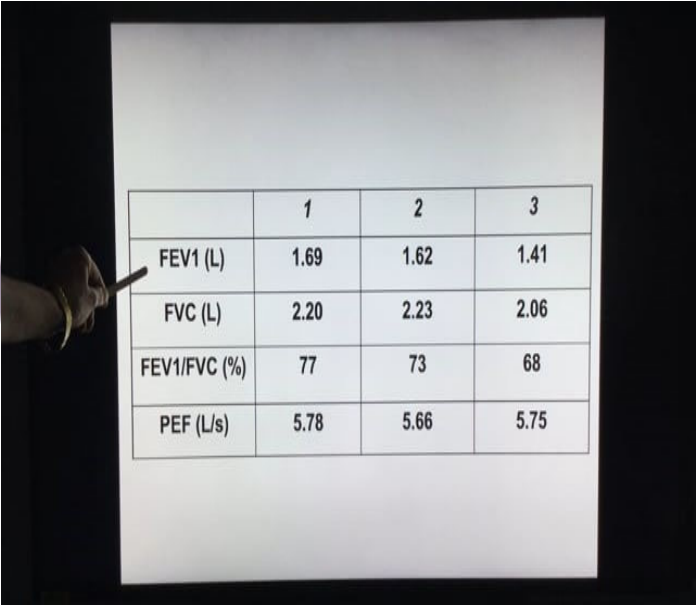

	1	2	3
FEV1 (L)	1.69	1.62	1.41
FVC (L)	2.20	2.23	2.06
FEV1/FVC (%)	77	73	68
PEF (L/s)	5.78	5.66	5.75

81

Between Manoeuvre Acceptability

Repeatable

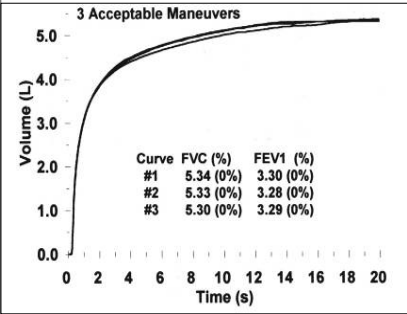

Curve	FVC (%)	FEV1 (%)
#1	5.34 (0%)	3.30 (0%)
#2	5.33 (0%)	3.28 (0%)
#3	5.30 (0%)	3.29 (0%)

Trial 1	FVC	FEV ₁
1	5.34	3.30
2	5.33	3.28
3	5.30	3.29

Acceptable repeatability: Difference between largest and next largest FVC and FEV₁ ≤ 150 ml (100 ml if FVC ≤ 1.0 L)

©IARS 2016

82

Between Manoeuvre
Acceptability

Non Repeatable

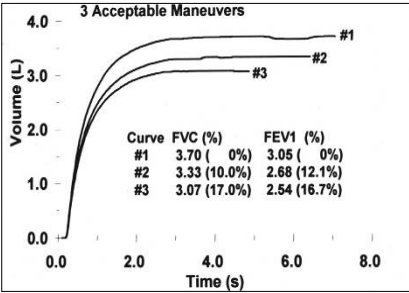

Trial	FVC	FEV ₁
1	3.70	3.05
2	3.33	2.68
3	3.07	2.54

Acceptable repeatability: Difference between largest and next largest FVC and FEV₁ ≤ 150 ml (100 ml if FVC ≤ 1.0 L)

©IARS 2016

83

Acceptability
and
Repeatability
Flow Chart

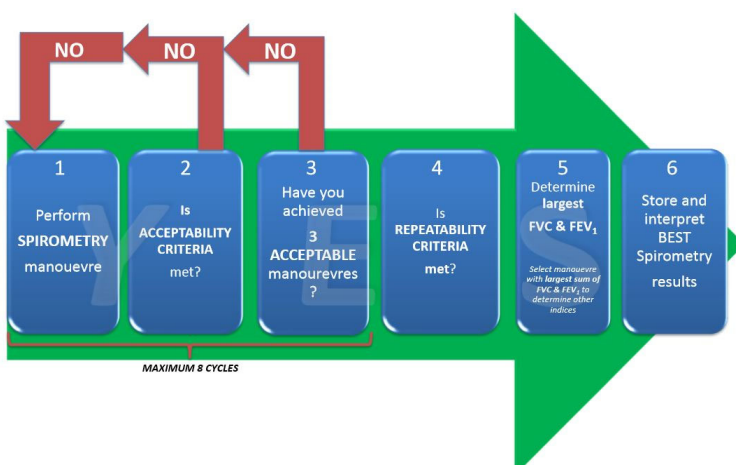

84



Spirometry demonstration and Practical Session

85

Get Valid Spirometry Results EVERY Time

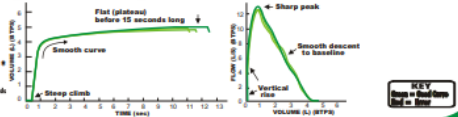

A Valid Test has:
3 or More Good Curves
and Repeatable FVC and FEV1

*The most current American Thoracic Society/ European Respiratory Society (ATS/ERS) standards.

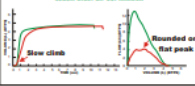
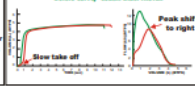
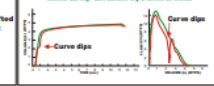
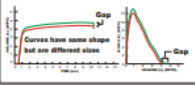
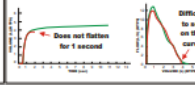
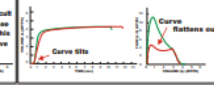
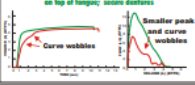
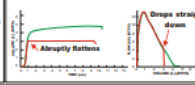
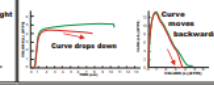
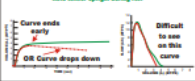

KEY
Steep or Shallow Climb
Flat or Rise

HOW TO CORRECT TEST ERRORS

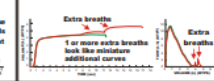
<p>Poor Initial Blast Coach: Blast air out HARDER</p> 	<p>Residualing; Slow Start; Large Extrapolated Volume Delete Curve; Coach: Blast FASTER</p> 	<p>Cough in First Second Delete Curve; Correction: by a drink of water</p> 
<p>Incomplete Inhalation Coach: Take a DEEPER breath</p> 	<p>No Plateau Before 15 Seconds Coach: Keep blowing until told to stop</p> 	<p>Inconsistent Effort Coach: One continuous blast and keep blowing</p> 
<p>Partially Occluded Mouthpiece Coach: Position mouthpiece between teeth and on top of tongue; secure dentures</p> 	<p>Glottic Closure or Breath Holding Coach: Initial BIG BLAST then RELAX and keep blowing</p> 	<p>Leak Correction: Check equipment and connections</p> 
<p>Negative Zero Flow Error Correction: Be still/lean through sensor when spirometer starting; hold sensor upright during test</p> 	<p>Positive Zero Flow Error Correction: Be still/lean through sensor when spirometer starting; hold sensor upright during test</p> 	<p>Extra Breaths Correction: BREATHE CORRECT; Use nose clips and lips tightly sealed</p> 

*Referencing on the Worker's protection, safety and health at work for all people through research and prevention.

NIOSH – The National Institute for Occupational Health and Safety

86

Error #1: Sub-maximal Inhalation

	FVC (L)	FVC % Pred	FVC LLN (L)	FEV ₁ (L)	FEV ₁ % Pred	FEV ₁ LLN (L)
Good Effort	4.90	96	4.17	4.17	103	3.29
Error	4.18	82	4.17	3.60	88	3.29

$4.90 - 4.18 = 0.72$

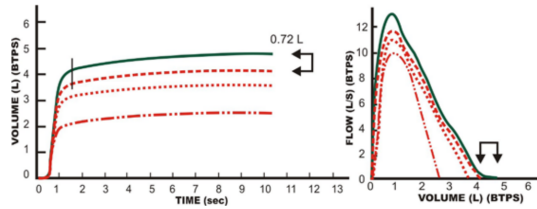

- Identify by Gap between FVC plateaus and space between ending points of FV curve
- Curves of different sizes
- ↓FVC falsely indicates restriction
- **Solution:** Coach the subject to FILL THEIR LUNGS, taking the deepest possible breath.
- **Spirometer Error Message:** "FVC variable", "FEV1 variable", or "Take a deeper breath."

Sub Maximal Inhalation

87

How to know your subject has taken a maximal breath.

- If the volume of the maximal inspiration (FIVC) after EOFE is greater than FVC, then the patient did not start the manoeuvre from TLC. FEV1 and FVC measurements from a manoeuvre with
- FIVC-FVC > 0.100L or 5% of FVC whichever is greater, are not acceptable (pg.79 of 2019 standards)
- **Trial 1:** FIVC (5.37) FVC (4.98)=390 ml greater
 - 5% of 4.98 is 4.98/100 *5 =249ml
- Unacceptable test- FVC and FEV1 likely to be underestimated
- **Trial 2 :** Acceptable
- **Trial 3:** Unacceptable 760 ml difference (allowance 231ml)
- Using FIVC reduced ratio from 82% to 77%- still Normal spirometry

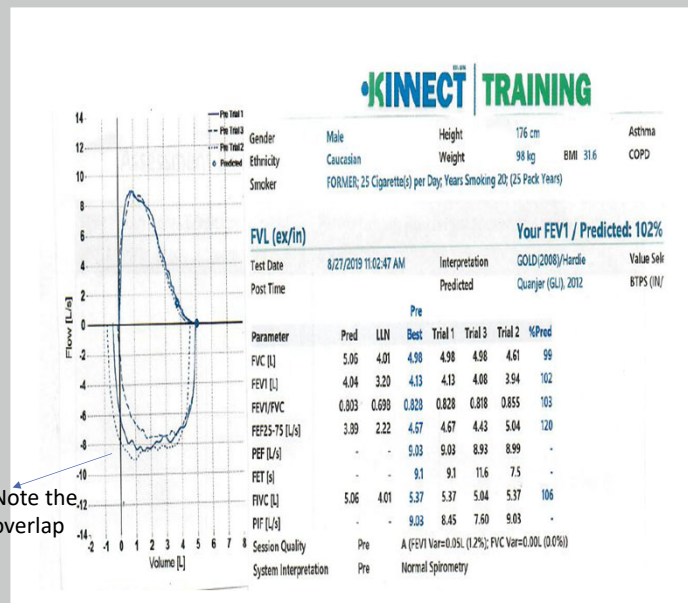

88

Is this test acceptable?

- FVC is 110ml higher
- 5% of FVC is 205ml
- Ratio would drop to 77% if using FVC
- Test is acceptable.
- Cough in trial 2 after 1st second, so acceptable
- Note: Subject only exhaled for 4 seconds but plateau and repeatability criteria reached.

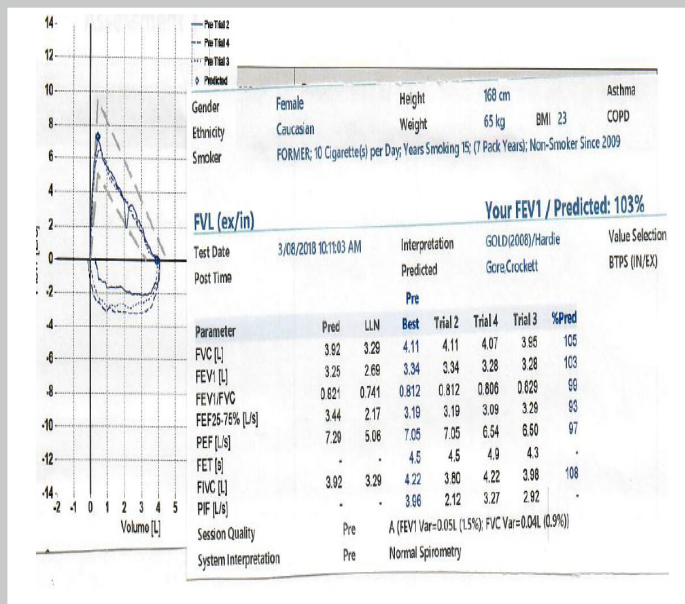

89

Acceptable Test

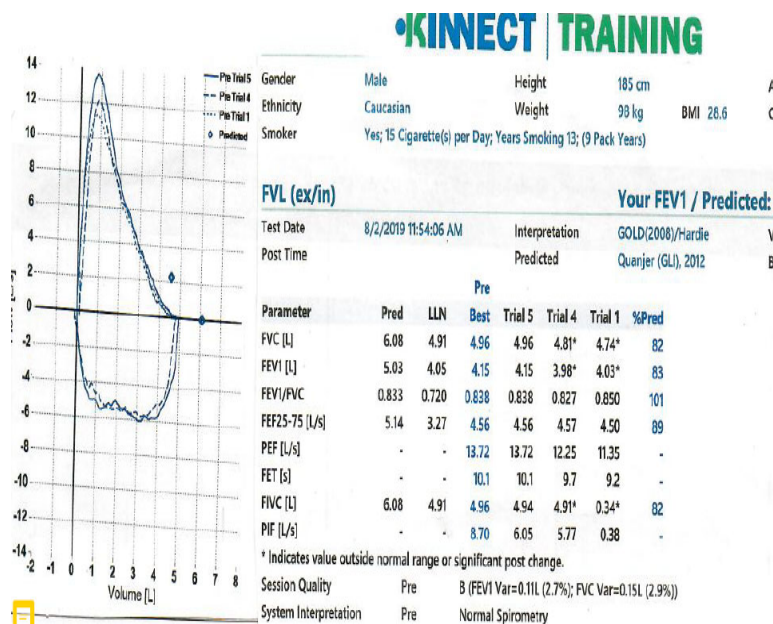

90

	FVC (L)	FEV ₁ (L)	FEV ₁ % Pred	PEF (L/sec)	Vext (L)	Vext (%)
Good Effort	4.79	4.12	86	12.2	0.12	2.5
Error	4.78	3.95	82	8.5	0.55	11.5

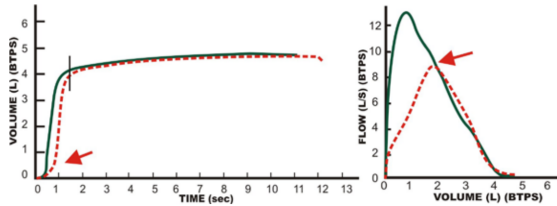

- Identify by displaced FV curve- it shifts to the right
- Extrapolated volume unacceptable –exceeds 0.15 or 5% of FVC whichever is larger
- Falsely ↑ FEV₁, Occasionally ↓
- **Solution:** Coach the subject to blast FASTER or IMMEDIATELY.
- **Spirometer Error Messages:** Most spirometers label this error with “Hesitation,” “Large extrapolated volume,” or “Start faster.”

Excessive Extrapolated Volume

91

	FVC (L)	FEV ₁ (L)	FEV ₁ % Pred	PEF (L/sec)
Good Effort	4.69	4.08	86	12.6
Error	4.57	3.36	71	4.1

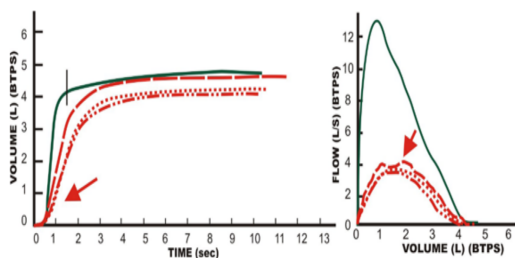

- Problem seen more clearly on FV curve
- The weaker the blast the lower the PEF
- ↓ FEV₁ and FEV₁/FVC ratio
- **Solution:** Coach the subject to blast the air out HARDER.
- **Spirometer Error Messages:** Spirometers may not label these curves as errors, so health professionals must recognize these patterns.
- ! A repeatable test may occur with sub maximal effort

Sub Maximal Effort

92

	FEV ₁ (L)	FEV ₁ % Pred
Good Effort	4.12	88
Error	3.96	84

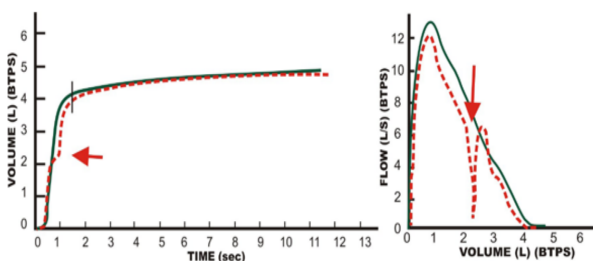

- Identify as jagged interruption in curve
- FEV₁ will be affected
- Can be used to validate FVC if consistent with others
- Easier to see on FV curve
- ↓↑ FEV₁ depending on strength of cough
- Significant coughing affects FVC also. FEV₁/FVC may be inaccurate
- **Solution:** Coughing is difficult to manage. Offering a drink of water before the manoeuvre may help.
- **Spirometer Error Message:** Some spirometers label this error with "Cough."
- Report trial with best PEF

Cough in the First Second

93

	FVC (L)	FVC % Pred	FEV ₁ (L)	FEV ₁ % Pred	FEV ₁ /FVC%
Good Effort	4.54	83	3.91	87	86
Error	3.81	67	3.76	84	98

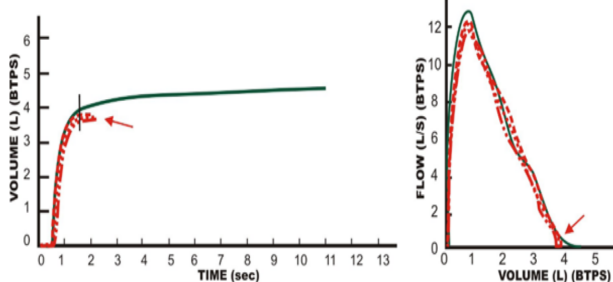

- Identify as lack of plateau on the VT curve
- Healthy >6 and obstructed patients longer (15 sec max)
- Falsely ↓ FVC indicating restriction
- Falsely ↑ FEV₁/FVC may cause true obstruction to be missed
- **Solution:** Coach the subject to KEEP BLOWING until told to stop.
- **Spirometer Error Message:** Spirometers may label this error as "Early termination" or "Keep blowing"

Remind subject that they will feel empty before they are, and that you can see when they are empty.

Early Termination

94

	FEV ₁ (L)	FEV ₁ % Pred	FEV ₁ /FVC%	PEF (L/sec)
Good Effort	3.73	86	88	10.8
Error	3.49	80	82	4.8

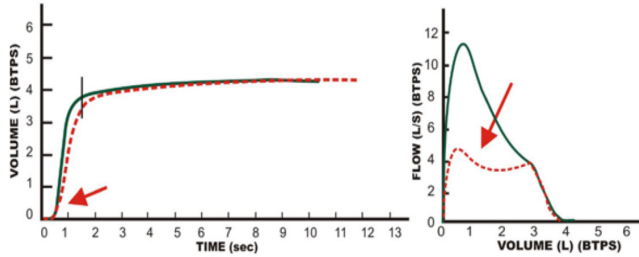

- Identify as a dip on the VT curve. The more variable the larger
- Falsely ↓ FEV₁ and FEV₁/FVC misinterpreted as obstruction
- Shape and ↓ PEF = poor effort
- **Solution:** Coach the subject to blast one breath out HARD and FAST and KEEP BLOWING out.
- **Spirometer Error Message:** Many spirometers do not label this error, so health professionals must recognize these patterns

Variable Effort

95

	FVC (L)	FVC % Pred	FEV ₁ (L)	FEV ₁ /FVC %
Good Effort	4.90	91	4.16	85
Error	4.40	82	4.16	96

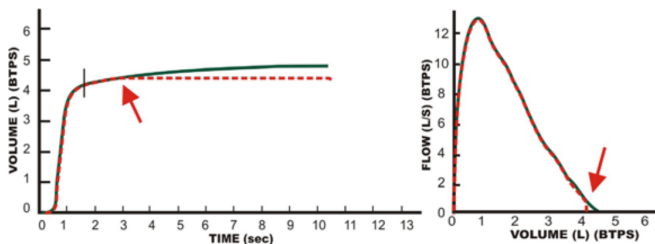

- VT curve shows an abrupt horizontal line, FV curve drops sharply to zero flow
- FVC ↓ indicating restriction. FEV₁/FVC ↑ therefore obstruction may be missed
- **Solution:** Glottic closure may be involuntary and should be documented. However, for breath holding, coach the subject to blow UNTIL TOLD TO STOP.
- **Spirometer Error Message:** Some spirometers will label this error with “Blow out longer” or “Abrupt stop.”

Cessation of Airflow. Glottic Closure or Breath-Holding

96

	FEV ₁ (L)	FEV ₁ % Pred	FEV ₁ /FVC%	PEF (L/sec)
Good Effort	4.08	101	87	12.4
Error	3.09	77	68	7.2

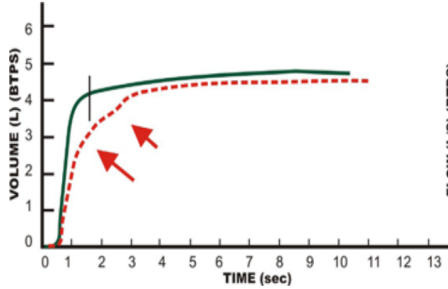
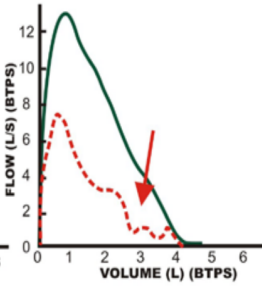



- Identify by ↓PEF, portions of curve are flattened
- FVC↓ and FEV₁/FVC↓ falsely indicating obstruction
- Solution:** Mouthpiece between teeth and on top of tongue. Secure/remove dentures
- Lightly bite mouthpiece
- Spirometer Error Message: Many spirometers will not label these curves as erroneous, so health professionals must recognize these patterns**
(You may hear a flutter like sound)

Partially Obstructed Mouthpiece

97

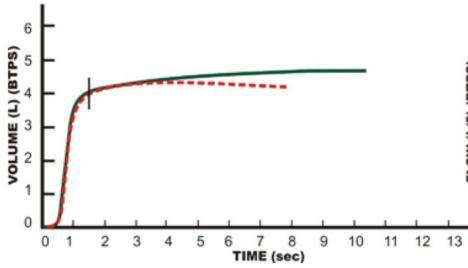
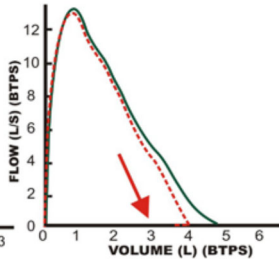
	FVC (L)	FVC % Pred	FEV ₁ (L)	FEV ₁ /FVC%
Good Effort	4.71	80	4.05	86
Error	4.35	74	4.05	93





- Leak in spirometer, hose or at the mouth
- Identify by descent in VT curve
- FV curve backtracks towards zero
- Affect on FVC is profound, FEV₁ unaffected
- FEV₁/FVC falsely ↑. May mask true obstruction or misinterpreted as restriction
- Solution:** Leak test (volume spirometers)
- Calibration and Linearity (low flow)
- Ensure tight lip seal. LISTEN!
- Spirometer Error Message: Spirometers do not label this error; it must be detected during a calibration check.**

Leak

98

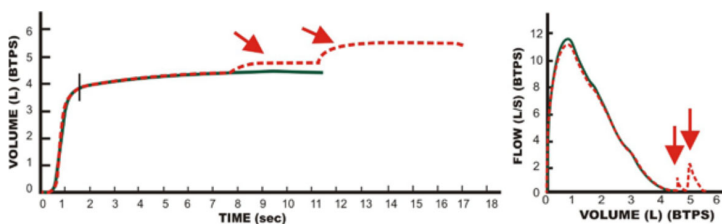
	FVC (L)	FVC % Pred	FEV ₁ /FVC%
Good Effort	4.43	97	88
Error	5.55	122	69



- Extra breath taken through nose or around mouth
- Seen on both displays, as steps in curve
- FVC↑, FEV1 not affected
- FEV1/FVC ↓ misinterpreted as obstruction
- **Solution:** Use nose clip, keep tight seal around mouthpiece
- Curves must be deleted otherwise they could be included with results
- **Spirometer Error Message: Spirometers do not label this error, so health professionals must recognize these patterns.**

Extra breath

99

	FVC (L)	FVC % Pred	FEV ₁ (L)	FEV ₁ % Pred	FEV ₁ /FVC%
Good Effort	4.41	85	3.87	95	88
Error	5.68	109	3.93	96	69

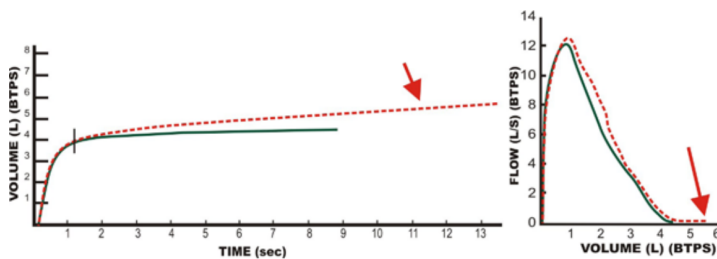

- Zero flow reference point set incorrectly
- VT curve to rise at a constant rate and never plateau
- FVC ↑ FEV1/FVC ↓ - falsely indicating obstruction
- **Solution:** Block sensor to prevent air motion. Hold upright and still
- Delete curves with zero flow errors
- **Spirometer Error Message: Spirometers do not label these errors, so health professionals must recognize these patterns.**

Positive Flow Error

100

	FVC (L)	FVC % Pred	FEV ₁ (L)	FEV ₁ % Pred	FEV ₁ /FVC%
Good Effort	4.41	85	3.87	95	88
Error	3.81	73	3.63	89	95

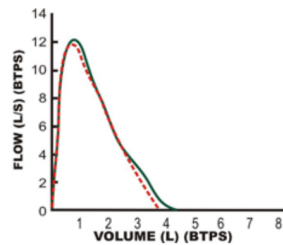
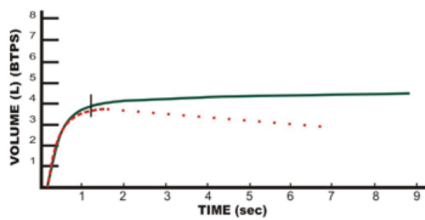

- A negative zero-flow error may cause the VT curve to end abruptly or it might drop gradually toward zero volume (left), like a large leak.
- FVC ↓ FEV₁/FVC ↑ - falsely indicating restriction or might hide true obstruction
- **Solution:** Block sensor to prevent air motion. Hold upright and still
- Delete curves with zero flow errors
- **Spirometer Error Message:** Spirometers do not label these errors, so health professionals must recognize these patterns

Negative Flow Error

101

Other Errors

- **Vocalisation** – you will hear vocal sounds during exhalation
 - **Solution:** Demonstrate manoeuvre with puffed cheeks “ like blowing candles out”
- **Opening mouth** - noticeable as no trace or very small trace
 - **Solution:** Remind subject to seal mouth, or use a flanged mouthpiece
- **Uncooperative patient** – at times subjects can not or will not perform test. May be due to mental health or possible lack of trying
 - **Solution:** The harder you blow the more damage we can see in the lungs

If acceptability criteria is not met after 8 trials document it “ Poor patient technique, best effort selected. Interpret with care!

REMEMBER TECHNICAL COMMENTS HELP WITH INTERPRETATION



102

Spirometry Induced bronchospasm

Airway Hyper-reactivity (asthma)

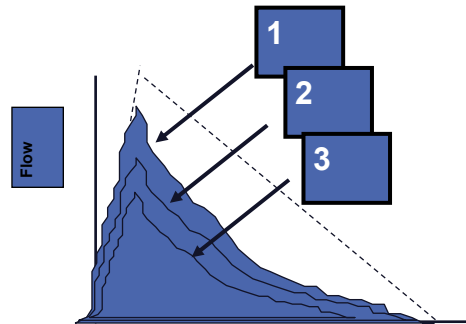

- Relieve with bronchodilator
- Note observation so physician can approve treatment for asthma
- ? Compliance

103

Data Selection

FEV1 from loop with best PEF

FVC – Largest VC. It can be selected from inspiratory or expiratory loop, or if obstructed perform an SVC

- *“The largest FVC and the largest FEV1 (BTPS) should be recorded after examining the data from all of the usable curves, even if they do not come from the same curve.”*

All other parameters and loop should be selected from loop which has the largest combined FVC and FEV1

104

Data Selection

- Remember to look at your loops, a slow start can give a higher FEV1!!

Larger VC can be obtained during slow manoeuvre due to small airway collapse → underestimation of FVC

Example

4/6 = 0.66 Ratio

4/6.5 = 0.61 ratio (more obstructive)

105

Grading your spirometry

Table 10. Grading System for FEV₁ and FVC (Graded Separately)
 Coal board medicals require A or B grade

Grade	Number of Measurements	Repeatability: Age >6 yr	Repeatability: Age ≤6 yr*
A	≥3 acceptable	Within 0.150 L	Within 0.100 L*
B	2 acceptable	Within 0.150 L	Within 0.100 L*
C	≥2 acceptable	Within 0.200 L	Within 0.150 L*
D	≥2 acceptable	Within 0.250 L	Within 0.200 L*
E	≥2 acceptable OR 1 acceptable	>0.250 L	>0.200 L*
U	0 acceptable AND ≥1 usable	N/A	N/A
F	0 acceptable and 0 usable	N/A	N/A

Definition of abbreviation: N/A = not applicable.

The repeatability grade is determined for the set of prebronchodilator maneuvers and the set of post-bronchodilator maneuvers separately. The repeatability criteria are applied to the differences between the two largest FVC values and the two largest FEV₁ values. Grade U indicates that only usable but not acceptable measurements were obtained. Although some maneuvers may be acceptable or usable at grading levels lower than A, the overriding goal of the operator must be to always achieve the best possible testing quality for each patient. Adapted from Reference 114.

*Or 10% of the highest value, whichever is greater; applies for age 6 years or younger only.

106

Table 7. Summary of Acceptability, Usability, and Repeatability Criteria for FEV₁ and FVC

Acceptability and Usability Criterion	Required for Acceptability		Required for Usability	
	FEV ₁	FVC	FEV ₁	FVC
Must have BEV \leq 5% of FVC or 0.100 L, whichever is greater	Yes	Yes	Yes	Yes
Must have no evidence of a faulty zero-flow setting	Yes	Yes	Yes	Yes
Must have no cough in the first second of expiration*	Yes	No	Yes	No
Must have no glottic closure in the first second of expiration*	Yes	Yes	Yes	Yes
Must have no glottic closure after 1 s of expiration	No	Yes	No	No
Must achieve one of these three EOFE indicators:	No	Yes	No	No
1. Expiratory plateau (\leq 0.025 L in the last 1 s of expiration)				
2. Expiratory time \geq 15 s				
3. FVC is within the repeatability tolerance of or is greater than the largest prior observed FVC [†]				
Must have no evidence of obstructed mouthpiece or spirometer	Yes	Yes	No	No
Must have no evidence of a leak	Yes	Yes	No	No
If the maximal inspiration after EOFE is greater than FVC, then FVC – FVC must be \leq 0.100 L or 5% of FVC, whichever is greater [‡]	Yes	Yes	No	No
Repeatability criteria (applied to acceptable FVC and FEV₁ values)				
Age $>$ 6 yr: The difference between the two largest FVC values must be \leq 0.150 L, and the difference between the two largest FEV ₁ values must be \leq 0.150 L				
Age \leq 6 yr: The difference between the two largest FVC values must be \leq 0.100 L or 10% of the highest value, whichever is greater, and the difference between the two largest FEV ₁ values must be \leq 0.100 L or 10% of the highest value, whichever is greater				

Definition of abbreviations: BEV = back-extrapolated volume; EOFE = end of forced expiration; FEV_{0.75} = forced expiratory volume in the first 0.75 seconds; FVC = forced inspiratory VC.

The grading system (Table 10) will inform the interpreter if values are reported from usable maneuvers not meeting all acceptability criteria.

*For children aged 6 years or younger, must have at least 0.75 seconds of expiration without glottic closure or cough for acceptable or usable measurement of FEV_{0.75}.

[†]Occurs when the patient cannot expire long enough to achieve a plateau (e.g., children with high elastic recoil or patients with restrictive lung disease) or when the patient inspires or comes off the mouthpiece before a plateau. For within-manoeuvre acceptability, the FVC must be greater than or within the repeatability tolerance of the largest FVC observed before this manoeuvre within the current prebronchodilator or the current post-bronchodilator testing set.

[‡]Although the performance of a maximal forced inspiration is strongly recommended, its absence does not preclude a manoeuvre from being judged acceptable, unless extrathoracic obstruction is specifically being investigated.

Summary of Acceptability, Usability, and Repeatability Criteria for FEV₁ and FVC

107

Dealing with Syncope during Spirometry

How to recognise syncope

- The following are signs that syncope is about to occur
- Colour drains from the face
- Patient appears to convulse slightly; this will then lead to patient losing consciousness and becoming flaccid. Patient will come around and may not be aware of “what just happened.”

108

Dealing with Syncope during Spirometry

- Chair
- Monitor closely
- Slow Vital Capacity – SVC
- Modified expiration technique – forcibly for 3 seconds then relax
- Increase rest period – 1 minute
- Document on the subject's test result:
 - *"Syncope occurred during spirometry, FVC may be underestimated" or*
 - *"Syncope occurred during spirometry; VC taken from an SVC manoeuvre"*
 - *Ensure to place a note on subjects file, so that future assessors are aware that the subject may experience syncope upon testing.*

109

To recap...

Acceptable tests are:

A good start of exhalation with extrapolated volume, <5% of FVC or 0.150 L, whichever is greater.

Free from artifacts

No cough during first second of exhalation (for FEV₁)

No glottis closure or abrupt termination (for FVC)

No early termination or cutoff (for FVC)

Maximal effort provided throughout the maneuver

No obstructed mouthpiece

110

Predicted Reference Values

Depend on accurate evaluation of:

- Height or arm span
- Age (natural aging effect)
- Sex (Women have smaller lungs)
- Race (often 10-20% less for non-Caucasians)
- Adult (>18 years)
- Pediatric (5-17 years)
- Obesity status (not essential but useful for interpretation)

111

Global Lung Initiative (GLI)

<p>The most recent comprehensive study was published in 2012</p> <ul style="list-style-type: none"> • First global multi-ethnic reference equations for spirometry that span all-ages. • Endorsed by five international societies. 	<p>74,187 healthy non-smokers (57.1% females) 40 countries Aged 3-95 years</p>
<p>Multi-ethnic reference equations using modern statistical methods, including development of age dependent lower limits of normal.</p>	<p>Previously each hospital selected their own preferred reference equations with which to interpret spirometry results.</p>
<p>However, since use of different equations has been shown to lead to different interpretation, this meant that results from any given individual could differ depending on where they were assessed.</p>	<p>These predicted values have been endorsed by all international Respiratory Societies including the Australian & New Zealand societies.</p>

112

Global Lung Initiative

- <https://www.spirometry.com/ENG/LLN-Z-SCORE/LLN-Z-SCORE.asp>

LLN and Z-SCORE: Normal Distribution and Percentile

When the data tend to be around a central value we have a **NORMAL DISTRIBUTION** with a bell-shaped curve.

Relationship between **STANDARD DEVIATION (SD)** and percentage of data under the curve in the case of a normal distribution.

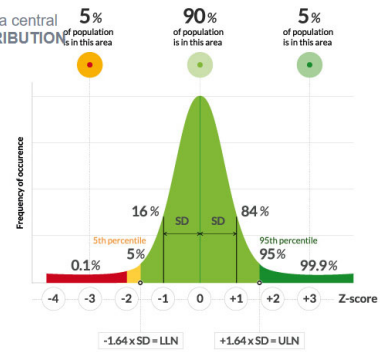

The central line is the position of the **MEAN** value.

- 50% of population is above this value
- 50% is below this value

113

Interpretation with GLI

The ATS/ERS guidelines recommend that the interpretation of spirometry measurements use the lower limit of normal (LLN) to detect an abnormality. The LLN represents data below the lower fifth percentile from a large healthy reference group.

A simple way to present spirometry results and their relationship to LLN is to express the results as Z-scores both numerically and using a pictogram

The Z-score represents how many SD the measured value is away from the mean predicted value (i.e. a Z-score of 0 represents the mean predicted value, while a Z-score of -1 would be one SD below the mean predicted value).

114

Interpretation with GLI

	Meas	LLN	Pred	% Pred
FEV ₁ (L)	3.16	2.16	3.04	104
FVC (L)	4.70	2.98	4.06	116
FEV ₁ /FVC (%)	67	62	75	

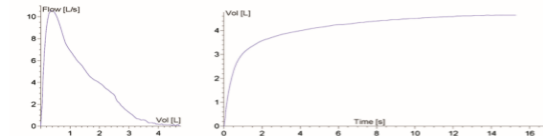

Figure 1 Spirometry results for a 73.4-year-old caucasian male (height of 176.6 cm) showing the measured values (Meas), lower limit of normal (LLN), predicted value (Pred), percent predicted value (%Pred) and Z-score for each parameter plotted on the bars. Both flow/volume and volumetime graphs are also shown.

Normal spirometry pattern

- The measured FEV₁/FVC is 67% which is above the LLN of 62%, with the GLI 2012 Z-score being -1.01.
- Therefore, the measured FVC is then evaluated and at 4.70 L (Z-score of 0.97), the FVC is also above the LLN of 2.98 L.
- Thus, this spirometry result is within the normal limits.
- The dots on the Z-score pictogram clearly show that all values are within the normal range. Although the measured FEV₁/FVC is <0.7, these spirometry results do not indicate an obstructive spirometric pattern because the LLN is 62% for this individual.

115



116



EST. 1996

KINECT TRAINING

Part 3
Spirometry Interpretation



117

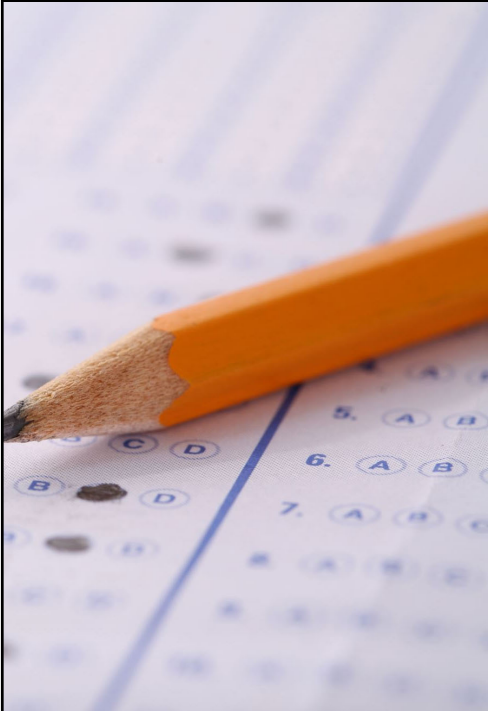

Spirometry Interpretation Overview





- Normal Pattern
- Types of ventilatory defects
- Algorithms for interpreting results
- Obstructive pattern
- Restrictive pattern
- Mixed pattern
- CWP/Silicosis – Video
- Quiz and case studies

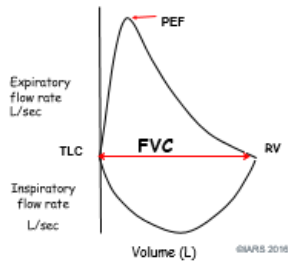

118

Normal Spirometry (Pg. 30 workbook)



- 
 TRIANGULAR SHAPE.
- 
 A STEEP AND RAPID VERTICAL RISE
- 
 OBSERVE THE SHARP POINT OF THE PEAK.
- 
 THIS IS AN IMPORTANT INDICATOR OF THE SUBJECT'S EFFORT.
- 
 SMOOTH CONTINUOUS DESCENT AT A 45 DEGREE ANGLE.
- 
 NOTE THE SHAPE OF THE CURVE FOLLOWS THE PREDICTED SHAPE OR THE 'DOTS'.

119

Interpretation of Results

Classification Of Ventilatory Abnormalities by Spirometry

	OBSTRUCTIVE	RESTRICTIVE	MIXED
FEV ₁	↓	↓ or Normal	↓
FVC	↓ or Normal	↓	↓
FEV ₁ /FVC	↓	↑ Normal or	↓

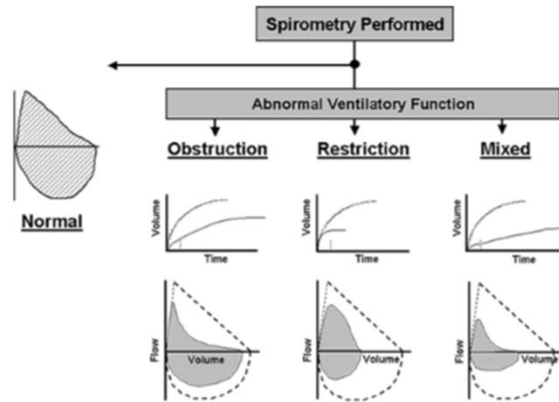

120

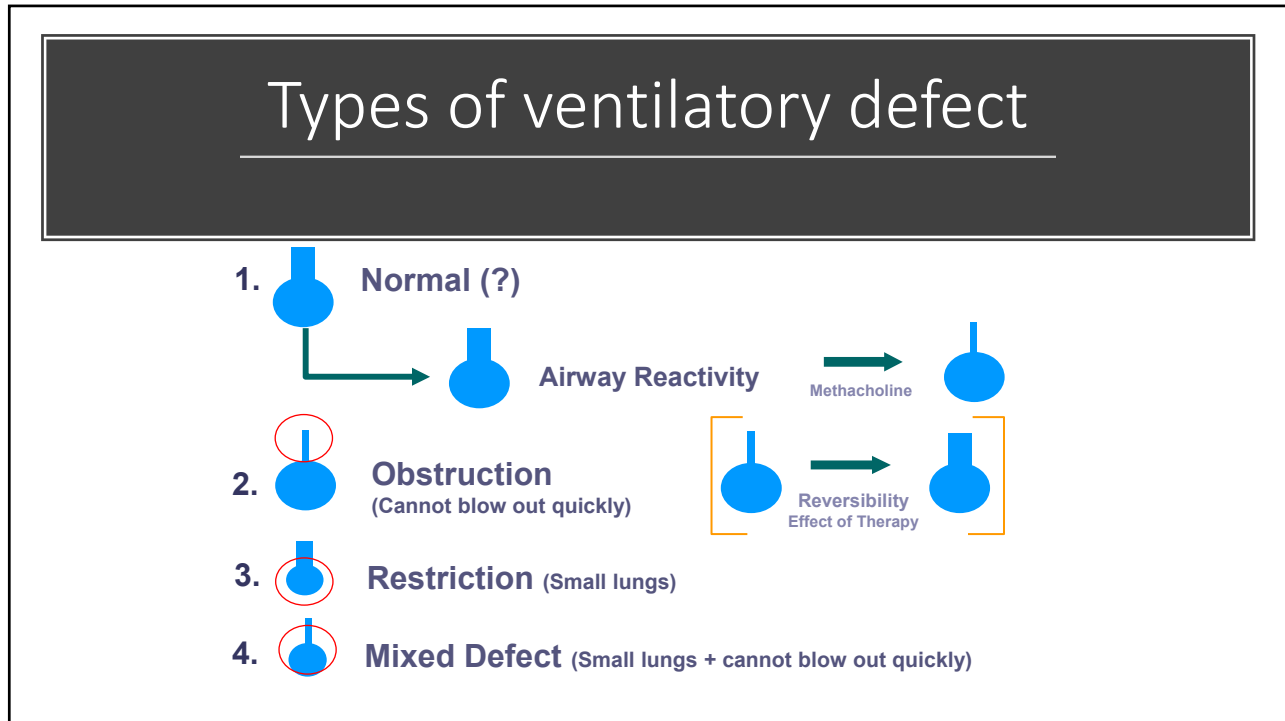

121

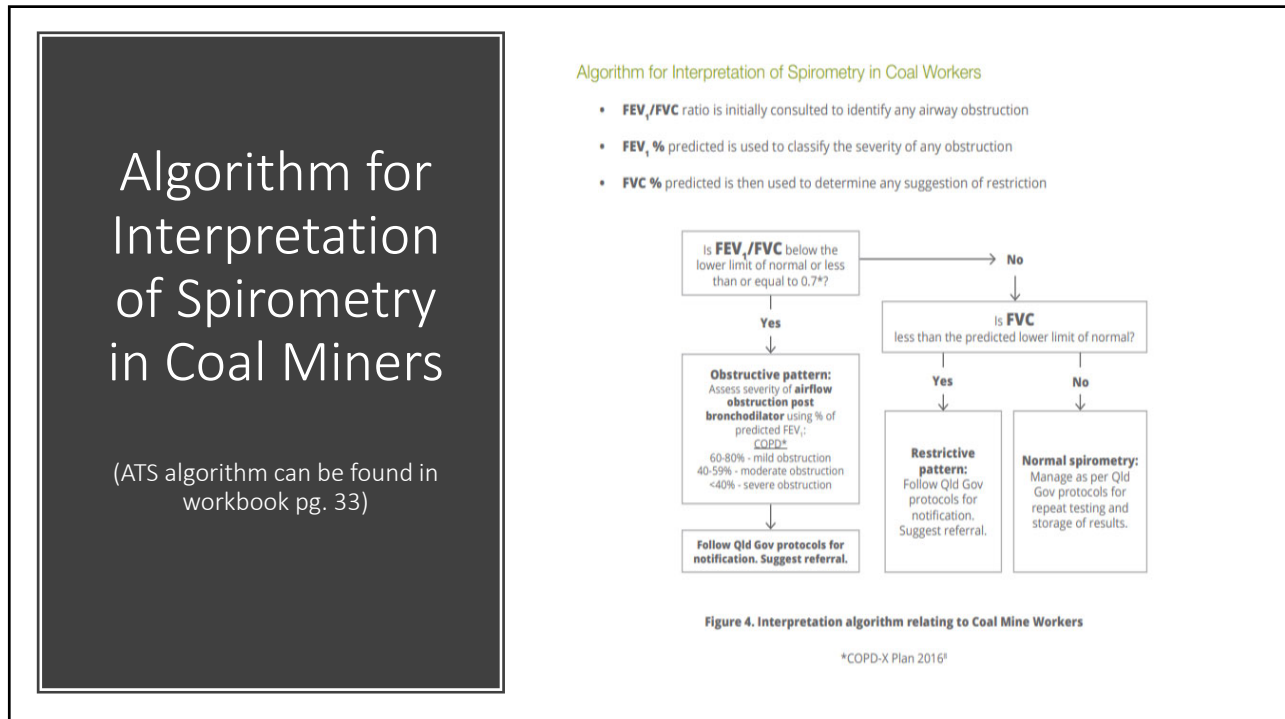

122

ATS versus GLI Severity classification

Proposed new grading system for categorisation of airways obstruction

Obstruction	Grade	ATS/ERS 2005	Proposed
Mild	1	>70% pred	z-score ≥ -2
Moderate	2	60–69% pred	-2.5 ≤ z-score < -2
Moderately severe	3	50–59% pred	-3 ≤ z-score < -2.5
Severe	4	35–49% pred	-4 ≤ z-score < -3
Very severe	5	<35% pred	z-score < -4
Mean grade		2.79	2.69

The conventional American Thoracic Society (ATS)/European Respiratory Society (ERS) recommended system 3 is based upon defining airways obstruction using forced expiratory volume in 1 s (FEV₁)/forced vital capacity (FVC) < lower limit of normal (LLN) and FEV₁ % predicted to classify severity. The proposed system is based upon defining airways obstruction using FEV₁/FVC < LLN and using z-scores for FEV₁ to classify severity.

<https://erj.ersjournals.com/content/43/2/505>

123

Coal Miners Clinical Pathway Guidelines

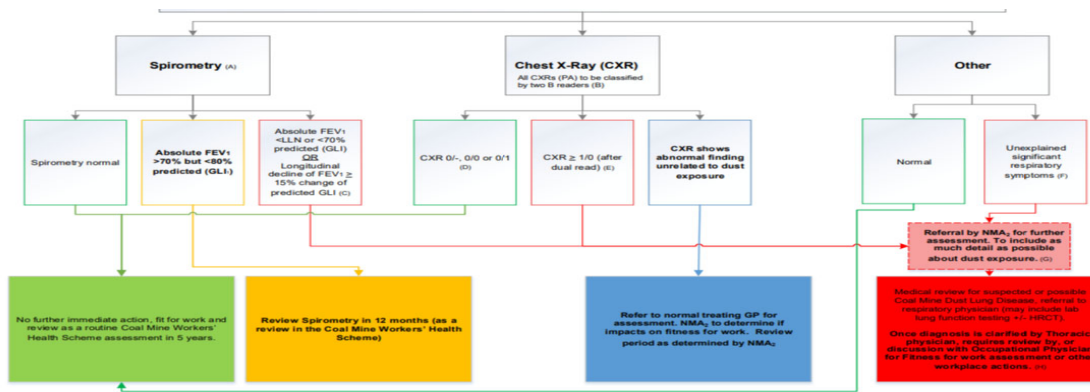

124



125

Longitudinal Monitoring of Lung Function

	% change in FVC L	% change in FEV ₁ L
Within a day		
Normal subjects	≥5	≥5
Obstructed workers	≥11	≥13
Week to week		
Normal subjects	≥11	≥12
Obstructed workers	≥20	≥20
Year to year	≥15	≥15

126

Obstructive Spirometry Curve

Concave shape- air can only be expelled slowly

Usually steep and rapid vertical rise, this can often match the predicted peak except in advanced disease.

Obstruction – Disease of the airways

Characterised by reduced expiratory flow rates, due to airway narrowing caused by either:

- Airway muscle constriction
- Increased mucus, or
- Airway inflammation

Volume of air within the lungs can still be normal but it takes longer to exhale through the narrowed airways.

But in advanced disease the small airways can collapse with exhalation and trap the remaining air in the lungs – causing a reduction in the air that is able to be exhaled.

Examples include Asthma and COPD (Chronic Obstructive Airways Disease).

127

Mild Obstruction

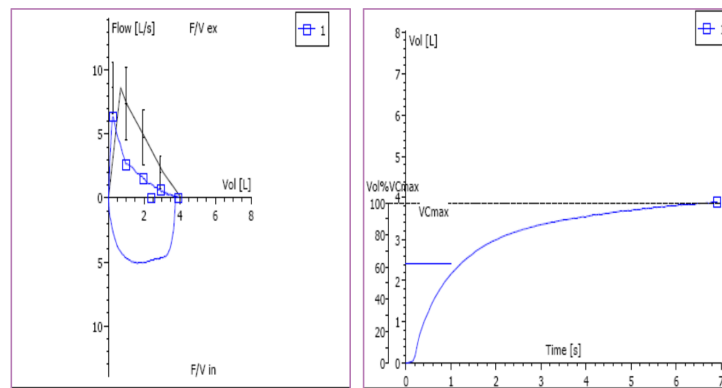

©IARS 2016

128

Severe Obstruction

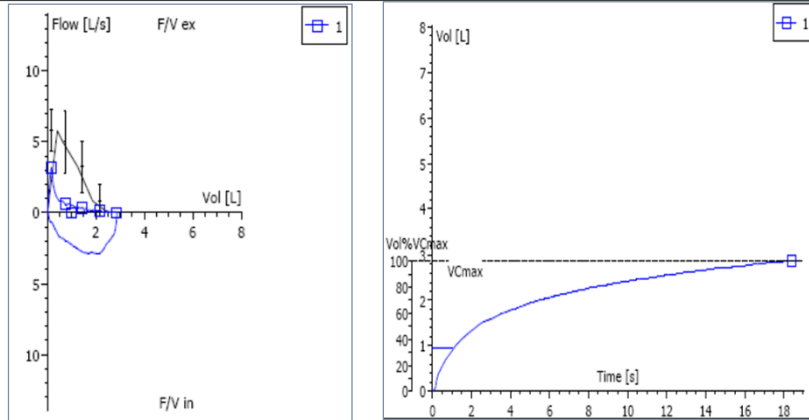

©IARS 2016

129

Differentiating Asthma and COPD

(Pg. 36 workbook)

Both airflow obstruction, the mechanisms of each disease are different.

In COPD due to emphysema, airflow obstruction is predominantly due to airway collapse

Asthma it is mainly due to bronchoconstriction, inflammation of the airway wall and mucous plugging.

Asthma – Reversible COPD – Little to no reversibility

Clinical history is also important in differentiating asthma from COPD.

Spirometry screening of smokers and ex-smokers has been shown to enhance early detection of COPD when treatment and intervention can have a positive effect on disease progression.

Motivate smokers to quit.

Normal spirometry does not exclude asthma.

130

Assessment of Reversibility

Not valid if patient just used bronchodilator (BD)

- Short acting β -agonist BD not used within 4 hrs of test
- Long acting β -agonists BD stopped 12 hrs prior to test

To assess bronchodilator reversibility:

- Perform pre-BD spirometry
- Administer BD (eg 4 puffs salbutamol) with MDI/spacer
- Wait 10-15 min salbutamol, >30 min ipratropium bromide
- Repeat spirometry

131

Reversibility Testing

The recommended criteria for a significant improvement in spirometry is at least:

- A 12% improvement in FEV1 (and/or FVC) and an absolute improvement of at least 200ml.
- The percentage improvement in FEV1 can be calculated as follows:

$$\frac{\text{Post BD FEV1} - \text{Pre BD FEV1}}{\text{Pre BD FEV1}} \times 100$$

132

Reversibility Calculation

FEV1 % CHANGE

- $\frac{2.37 - 2.04}{2.04} \times 100 = 16\%$
- 2.04

- 330 ml and 16% = Significant

FVC % CHANGE

- $\frac{4.05 - 3.91}{3.91} \times 100 = 3.5\%$
- 3.91

- 140 ml and 3.5% = not significant

Parameter	Unit	Pred	Test 1	Test 2	Test 3	Test 4	Test 5
FEV1	L	3.67	2.37	2.93	2.94		
FVC	L	4.83	4.05	3.98	3.96		
FEV1/FVC	%	76.3	58.6	77%	77%		
EV	L	0.000	0.073	0.084	0.091		
PEP	L/S	9.38	5.35	5.26	5.40		
PEP25-75	L/S	2.68	1.01	1.04	0.96		
FEV1/VC	%	76.3					

133

Is there significant reversibility?

- **FEV1** **FVC**
- PRE = 0.86 PRE = 1.80
- POST = 0.98 POST = 1.81

$$\frac{\text{Post BD FEV1} - \text{Pre BD FEV1}}{\text{Pre BD FEV1}} \times 100$$



134

Dynamic Compression

(Pg. 37 workbook)

- ✓
 Chronic inflammation → structural changes and narrowing
- ⬇
 Destruction of alveolar walls ↓support of small airways and decreases lung elastic recoil
- ⚠
 Airways unable to remain open during expiration due to loss of elasticity causing the airways to collapse when forced exhalation occurs
- !
 REASON WHY IT IS GOOD PRACTICE TO PERFORM A SLOW VC ON OBSTRUCTED PATIENTS

135

Dynamic Compression

The diagram shows a cross-section of a lung model labeled 'PhQuanter'. A yellow vertical bar on the left represents the chest wall. A red horizontal line at the top indicates the level of the pleural pressure during forced expiration from Total Lung Capacity (TLC). A blue line represents the airway pressure, which is lower than the pleural pressure in the peripheral airways, causing them to collapse. The airway pressure is higher than the pleural pressure in the central airways, which remain open.

136

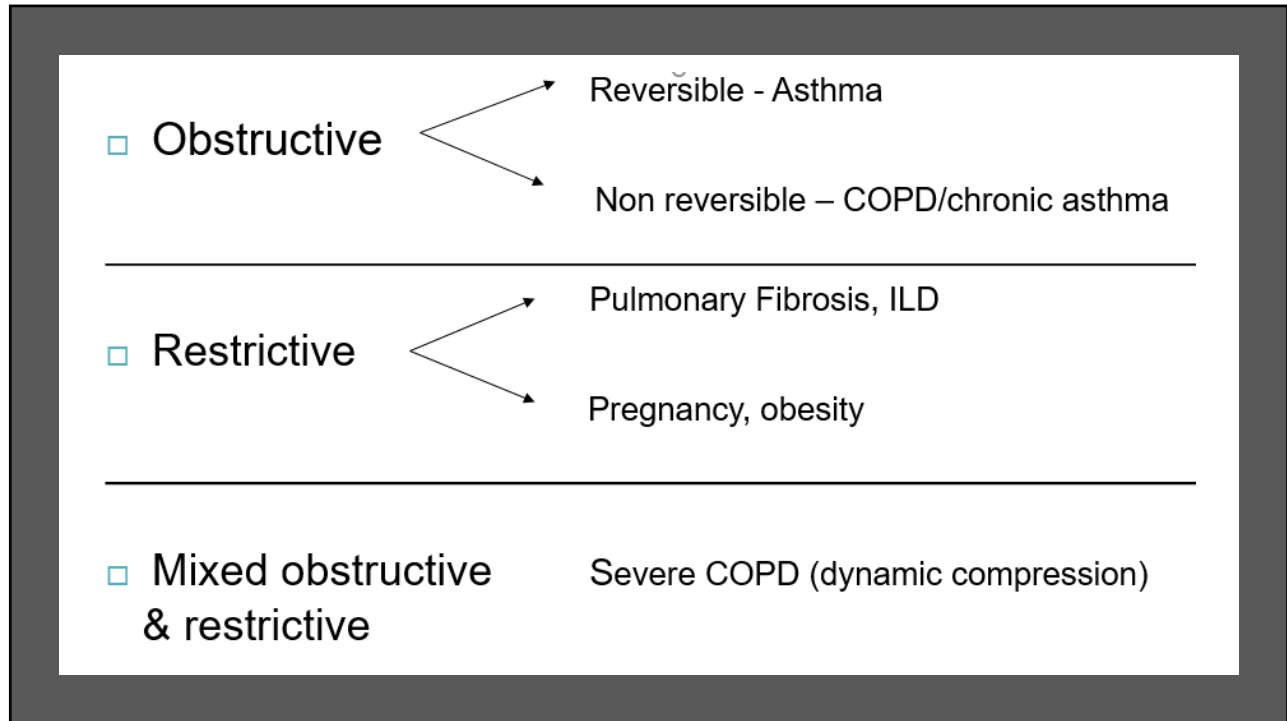

137

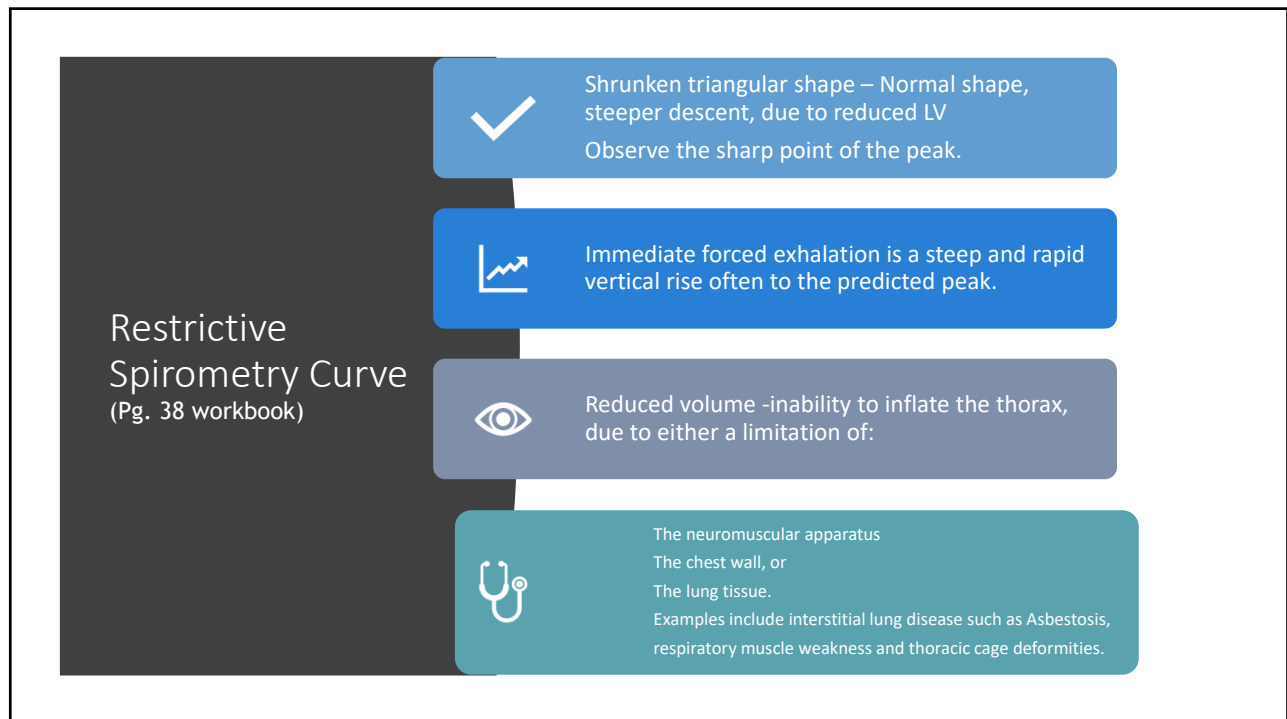

138

Restrictive Lung Disease

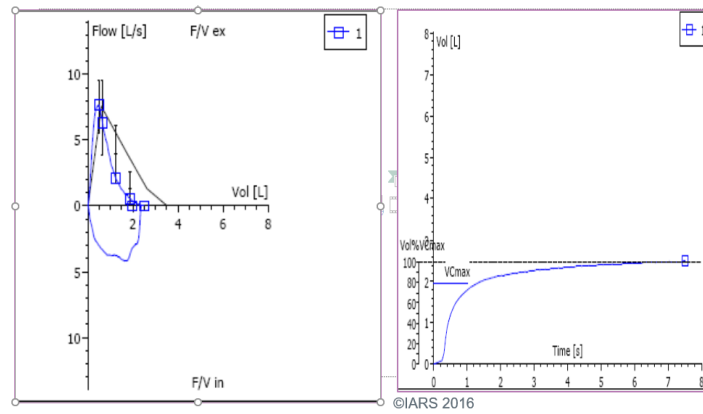

139

Mixed

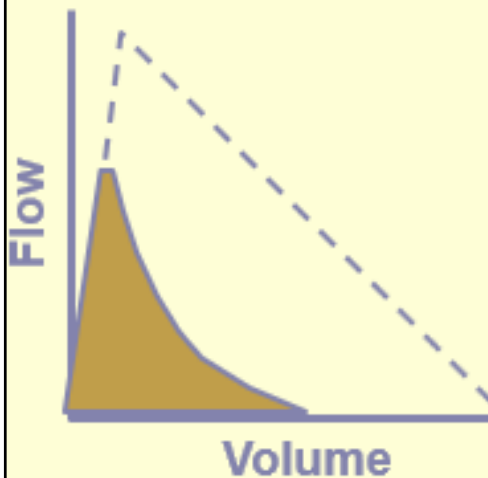

The mixed Obstructive and Restrictive Spirometry curve is characterised by both airflow obstruction and loss of lung volume.



This defect is relatively uncommon.



An example is cystic fibrosis.

140

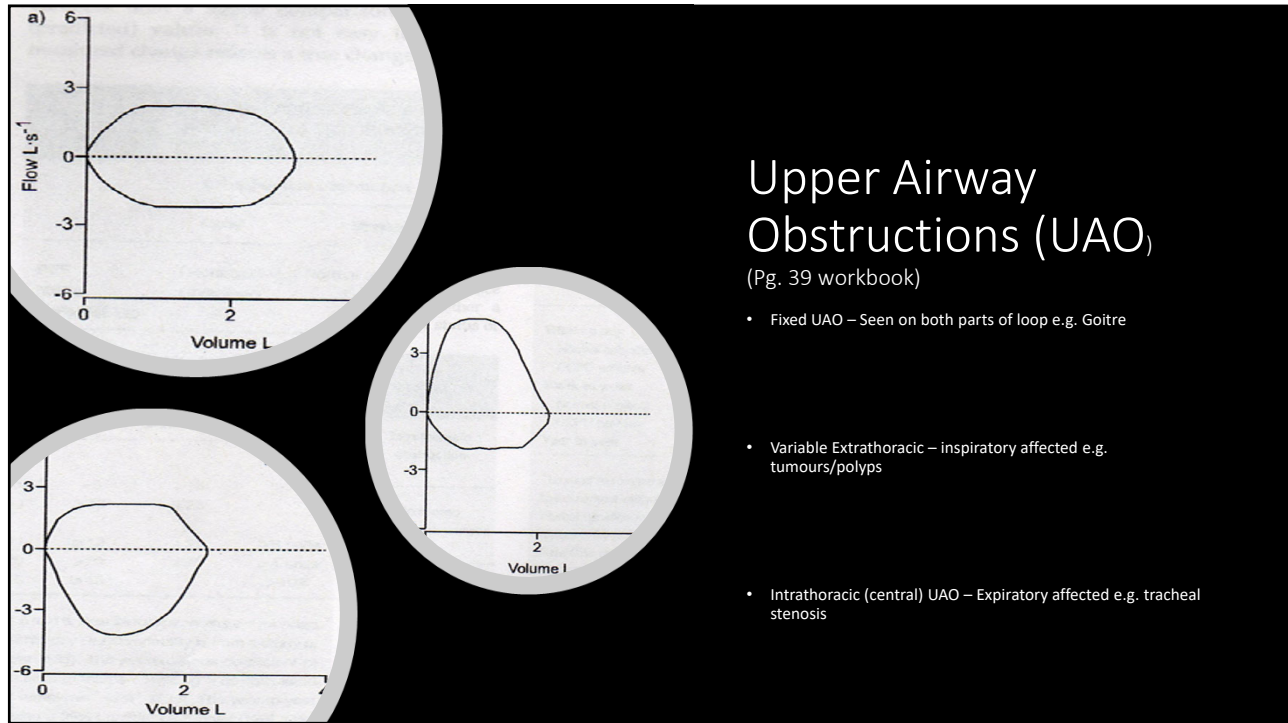

141

Black Lung – Coal Workers Pneumoconiosis (CWP)

Healthy Tissue Healthy Tissue 90-year-old schoolteacher Progressive massive fibrosis 40-year-old-miner

Since May 2015, there have been six confirmed cases of coal workers’ pneumoconiosis (CWP), one form of coal mine dust lung disease (CMDLD), reported among former and current Queensland coal mine workers, and the outcome of at least one suspected case is still pending.

Prolonged Exposure → coal mine dust lung disease, which includes CWP, emphysema, chronic bronchitis, and lung function impairment.

These diseases develop gradually, usually after at least 10 years of exposure, however in sensitive miners or in cases of intense exposure symptoms may occur sooner.

Typical symptoms :- include cough, sputum production, and shortness of breath,

Early Disease may be asymptomatic but still show findings on PFT’s and x- ray

! Early detection if key

Individuals who are or have been coal mine workers and are suspected of having CWP should be referred to a Respiratory and/or Occupational physician for further assessment.

142

Black Lung – Coal Workers Pneumoconiosis (CWP)



Figure 3: Underground mine and main locations of NMAs in Queensland (Figure courtesy of DNRM)

Review of Respiratory Component of Coal Mine Workers' Health Scheme

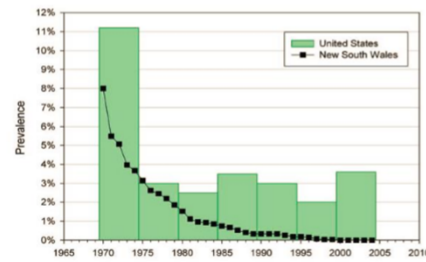

Figure 1: Prevalence of pneumoconiosis, ILO category 1/0 or greater among US underground coal miners and New South Wales coal industry employees, by year [19]

143



144



145

References/Links

See last page of Learner Workbook

The image shows a close-up, slightly angled view of several thick, antique-style books. The pages are heavily yellowed with age, and the spines are made of dark, worn leather. The books are stacked or lined up, with their edges creating a rhythmic pattern of light and shadow. The lighting is warm, highlighting the texture of the paper and the grain of the leather.

146

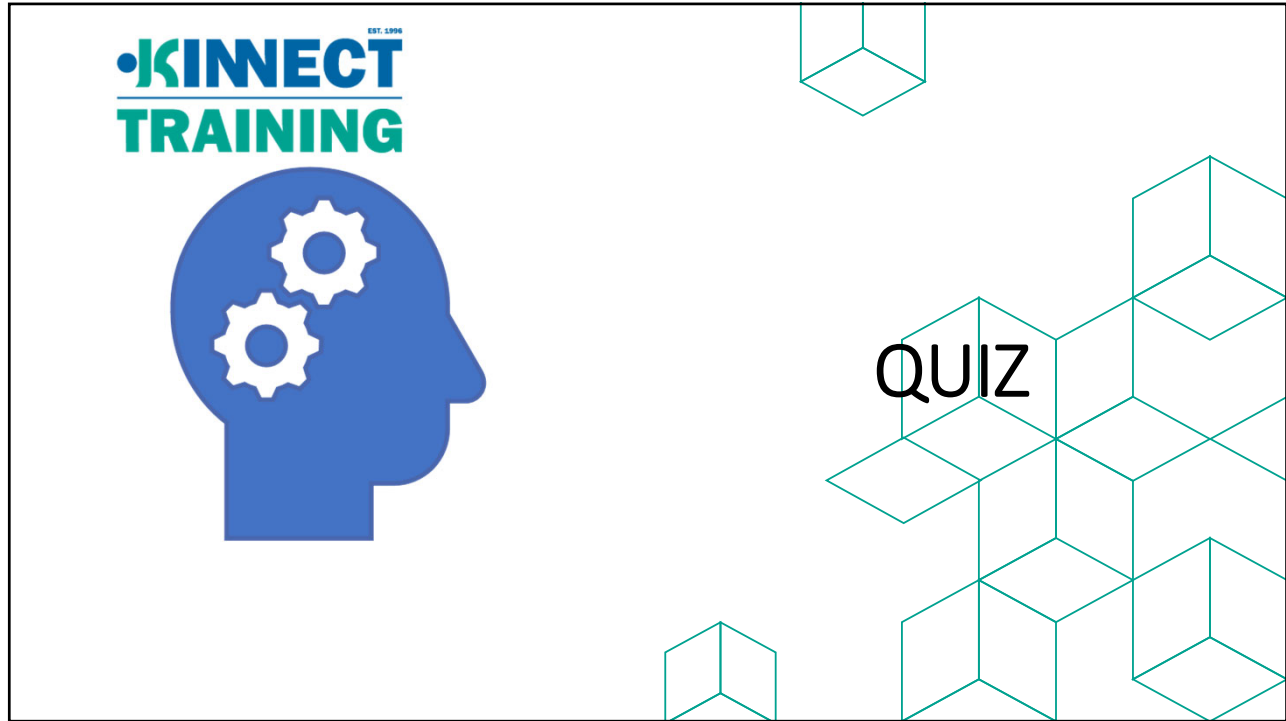

147

Activity Case Study 1

Male, 73 year old, 65 pack years. Hx of SOB, Chest infections, cough, x 2 hosp. admissions

The graph plots Flow (L/sec) on the y-axis (0 to 12) against Volume (L) on the x-axis (0 to 4). Three curves are shown: a dotted line for 'Predicted', a solid line for 'Pre-BD', and a dashed line for 'Post-BD'. The predicted curve peaks at approximately 6.5 L/sec at 0.5 L volume. The Pre-BD curve peaks at approximately 2.5 L/sec at 0.5 L volume. The Post-BD curve is nearly flat, indicating severe airflow limitation.

	Predicted		Pre-BD	Post-BD
	Mean	LLN		
FEV ₁ L	2.45	1.77	0.85 (35%)	0.90 (37%)
FVC L	3.42	2.61	2.10 (61%)	2.20 (64%)
FEV ₁ /FVC %	73	63	40	41
FEF _{25-75%} L/s	1.8	0.4	0.9	0.9
PEF L/s	6.7	4.7	2.2 (33%)	2.6 (39%)

148

Severe COPD

	Predicted		Pre-BD	Post-BD
	Mean	LLN		
FEV ₁ L	2.45	1.77	0.85 (35%)	0.90 (37%)
FVC L	3.42	2.61	2.10 (61%)	2.20 (64%)
FEV ₁ /FVC %	73	63	40	41
FEF _{25-75%} L/s	1.8	0.4	0.9	0.9
PEF L/s	6.7	4.7	2.2 (33%)	2.6 (39%)

- FEV₁/FVC < LLN → Obstruction
- FEV₁ 35% → V Severe (ATS)
- FVC → Also below LLN
- No significant reversibility
- Deep concave shape
- With this degree of airflow obstruction the reduced FVC is probably a consequence of airway closure, i.e. it is unlikely to be due to small lungs
- TLC performed – 132% predicted- confirms hyperinflation due to gas trapping

149

Pathophysiology

In COPD the airflow limitation is due to:

- Inflammatory thickening and distortion of the airway walls (smokers small airway disease)
- Expiratory collapse of airways due to loss of elastic support (emphysema)

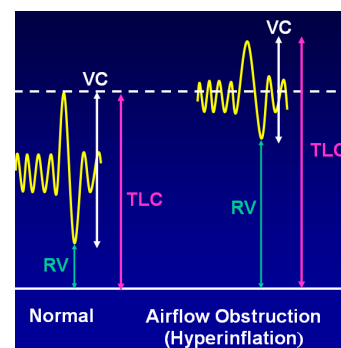
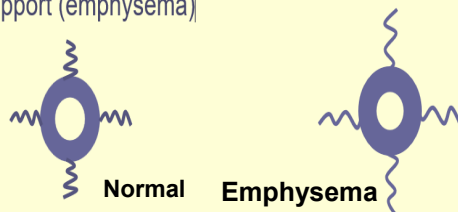

150

Activity Case Study 2

Non smoker, no past history or respiratory problems, 5 years of joint aches and morning stiffness, recent chest x ray shows diffuse lung infiltrate, referred for dyspnoea

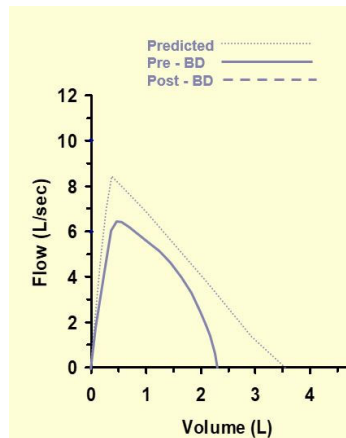

	Predicted		Pre-BD	Post-BD
	Mean	LLN		
FEV ₁ L	3.30	2.66	2.10 (64%)	2.15 (65%)
FVC L	4.06	3.31	2.35 (58%)	2.40 (59%)
FEV ₁ /FVC %	82	73	89	90
FEF _{25-75%} L/s	3.3	2.0	4.1	4.3
PEF L/s	7.4	5.6	6.3	6.4

151

Restrictive Lung Disease

	Predicted		Pre-BD	Post-BD
	Mean	LLN		
FEV ₁ L	3.30	2.66	2.10 (64%)	2.15 (65%)
FVC L	4.06	3.31	2.35 (58%)	2.40 (59%)
FEV ₁ /FVC %	82	73	89	90
FEF _{25-75%} L/s	3.3	2.0	4.1	4.3
PEF L/s	7.4	5.6	6.3	6.4

- Reduced FVC and FEV1 → below LLN
- Preserved ratio (89%)
- No significant change after bronchodilator
- Curve looks normal shape but small
- TLC performed -64% pred confirming restriction
- Patient found to have fibrosing alveolitis associated with rheumatoid arthritis
- Supranormal flow rates due to increased traction on the airways from the scar tissue causing distension of the airways
- LV reduced because overall size of lungs is restricted by inflammatory and fibrotic scar tissue

152

GLI interpretation Activity

Roger (57 years) has just been released from prison. He is coming to see you because he is short of breath walking up and down the local beach; he wonders if he has lost fitness during his time in prison.

Use coal miners algorithm Pg.32

Respiratory Physiology Laboratory

Canterbury
District Health Board
To: Pouni Houora O Waitaha

Phone: 03 364 0874 Ext: 80874
Fax: 03 364 0878 Ext: 80878
Email: resp@dhb.health.nz

Christchurch Hospital

Height: 187 cm Date of Birth: 11/01/1958
 Weight: 53.6 kg Age: 57 Years
 BMI: 15.33 Gender: male
 Ethnicity: Caucasian Test date: 31/08/2015

Technical Comments
End of test plateau not achieved. FVC may be underestimated. All other spirometry test criteria have been met.

Spirometry (Spirometry ref: GLI 2012, Caucasian)						
	Measured	LL	Pred	% Pred	Post	% Chg
FEV 1 [L]	1.04	3.13	4.11	25		
FVC [L]	4.54	4.10	5.35	85		
FEV 1 % FVC [%]	23	66				
FET 100 [sec]	20.9					

	Z-Score	-3	-2	-1	Z-Score	1	2	3
FEV 1 [L]	-4.70							
FVC [L]	-1.06							
FEV 1 % FVC [%]	-5							
FET 100 [sec]								

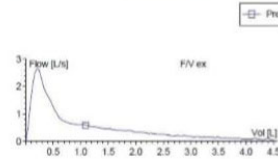
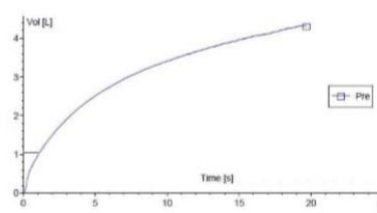
153

ANSWERS

Please list equipment requirements

- Nose clip
- Stadiometer and scales
- Disposable mouthpiece/Spirette
- Certified validated 3L Calibration syringe
- Spirometer meeting ATS/ERS requirements
- Disinfecting wipes
- Bronchodilator and spacer

How would you ensure that your equipment is functioning properly prior to commencing the test?

- 3 L syringe check
- BTPS correction – have correct ambient conditions been entered?
- Biological QC
- Linearity Check (Flow sensing)

What other measures are taken prior to commencing spirometry?

- Check contraindications
- Measure height and weight correctly
- Check ethnicity
- Check if bronchodilator medications have been taken
- Ensure patient is in correct testing position

154

ANSWERS

What type of defect is represented in the report?

- The FEV1/FVC ratio of 23% is well below LLN of 66%. Indicating an obstructive defect

Can you comment on the technical comments made. Will this make any difference to his result?

- End of test plateau not met – but after 21 seconds of exhalation this is unlikely to make a clinical difference

Can you classify the disease defect using the following guideline?

- Based on FEV 1 25% indicating severe airway obstruction

What other test would have been useful in this case?

- Spirometry before and after the administration of a bronchodilator would be useful to identify any reversibility of the airways obstruction

155

Case 1

Case history

Male

25 years, height 175 cm

Never smoked

No history of respiratory disease

Normal chest x-ray

Referred for pre-employment lung function tests

156

Case 1: Results

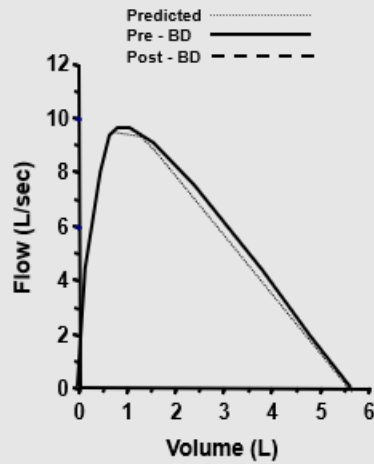

	Predicted		Pre-BD	Post-BD
	Mean	LLN		
FEV ₁ L	4.44	3.67	4.35 (98%)	-
FVC L	5.36	4.46	5.60 (104%)	-
FEV ₁ /FVC %	83	73	78	-
FEF _{25-75%} L/s	4.6	3.1	5.3	-
PEF L/s	10.0	7.7	9.8	-

157

Case 1 : Interpretation

Interpretation: Normal ventilatory function

The shape of the flow volume loop and all spirometric indices are within the normal range

These results indicate normal ventilatory function

This provides useful baseline lung function data for future comparison

158

Case 2

Case history

Male

35 years, height 163 cm

Smoker for 15 years; estimated consumption of 12 pack years

No significant history of respiratory disease other than occasional URTI and productive cough in morning

Attended GP for unrelated reason

159

Case 2 : Results

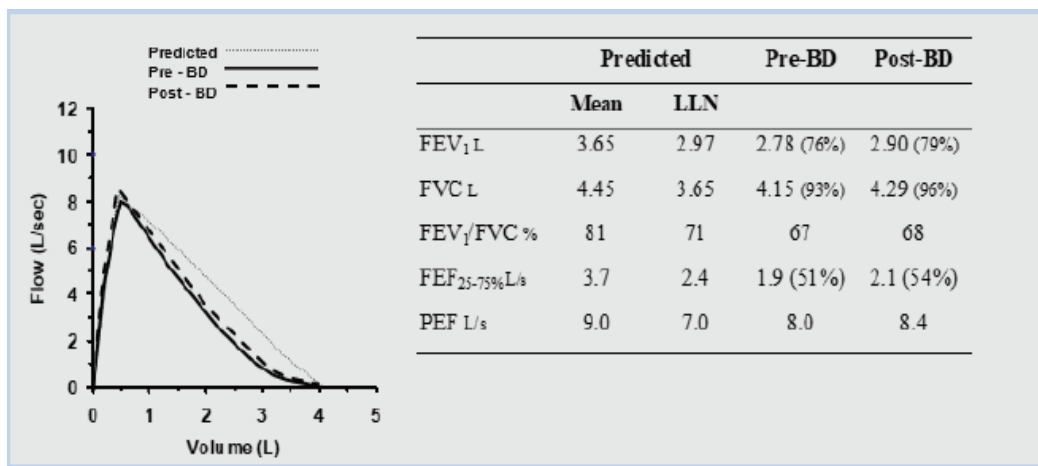

160

Case 2 - Interpretation

The reduced FEV₁/FVC ratio (67%) and slight concavity in the flow volume curve indicates airflow obstruction

The pre-bronchodilator FEV₁ is 76% and FEF_{25-75%} only 51% indicating mild airflow obstruction

Post-bronchodilator there was little improvement in FEV₁ (change in FEV₁ = 3% and 0.12 L)

Together with his smoking history, these results suggest mild COPD

What would your recommendations to him be?

161

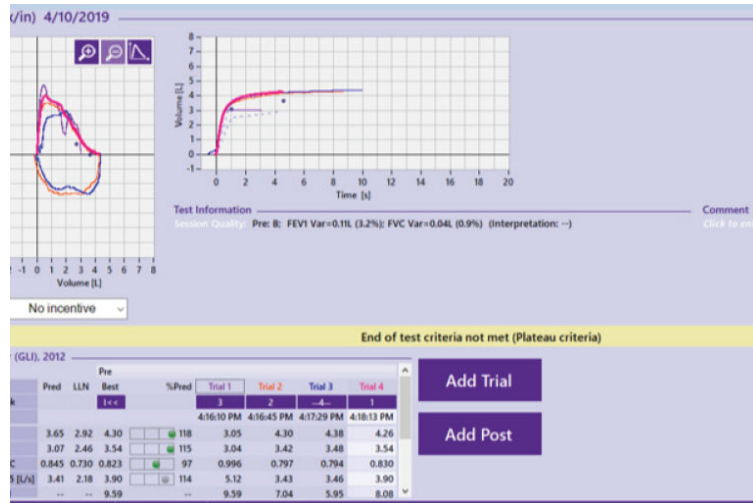

Is this test acceptable and reproducible?

162

Question 1

Which of the following are recommended as quality assurance procedures to verify the accuracy of spirometry measurements?

- A. Calibration (or verification) with a syringe
- B. Regular measurement of spirometry on a subject with no known lung disease (biological control)
- C. Use of bacterial filters
- D. Maintenance of a log of calibration results

A only

B only

D only

A and C

A, B and D

163

Answer

Which of the following are recommended as quality assurance procedures to verify the accuracy of spirometry measurements?

- A. Calibration (or verification) with a syringe
- B. Regular measurement of spirometry on a subject with no known lung disease (biological control)
- C. Use of bacterial filters
- D. Maintenance of a log of calibration results

A,B and D

164

Question 2

Acceptable repeatability of the FVC manoeuvre is reached when:

- A. The largest and next largest FVC are within 150 mL
- B. The largest and next largest FEV₁ are within 150 mL
- C. A maximum of 8 tests have been completed
- D. The FVC and FEV₁ are within 500mL of each other

A only

A and B

A and D

A, B and C

165

Answer

Acceptable repeatability of the FVC manoeuvre is reached when:

- A. The largest and next largest FVC are within 150 mL
- B. The largest and next largest FEV₁ are within 150 mL
- C. A maximum of 8 tests have been completed
- D. The FVC and FEV₁ are within 500mL of each other

A and B

166

Question 3

- A subject performs spirometry with the following results (volumes and flows are given after correction to BTPS).

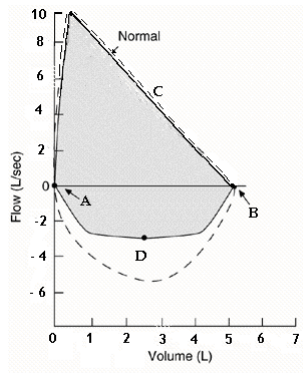

- 4.1 What is the FVC?
- 4.2 What is the PEF?
- 4.3 Which point on the graph (A or B) represents the point where the person was at full lung inflation?
- 4.4 Which point on the graph (A or B) represents the point where the person was at full expiration?

167

Answer

- A subject performs spirometry with the following results (volumes and flows are given after correction to BTPS).

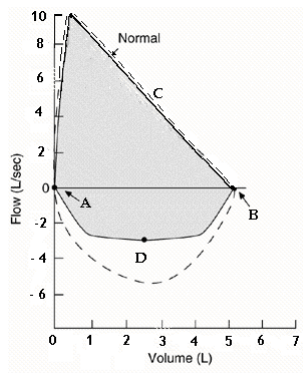

- 4.1 What is the FVC? **5L or B**
- 4.2 What is the PEF? **10L/s**
- 4.3 Which point on the graph (A or B) represents the point where the person was at full lung inflation? **A**
- 4.4 Which point on the graph **B** (A or B) represents the point where the person was at full expiration?

168

Question 4

- Match each flow–volume curve with the most likely ventilatory defect

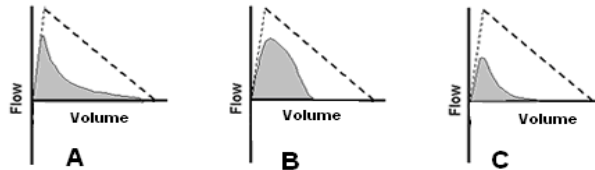

Ventilatory defect	Curve
10.1 Mixed obstructive / restrictive disease	
10.2 Obstructive disease	
10.3 Restrictive disease	

169

Answer

- Match each flow–volume curve with the most likely ventilatory defect

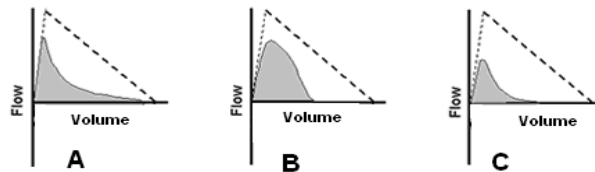

Ventilatory defect	Curve
10.1 Mixed obstructive / restrictive disease	C
10.2 Obstructive disease	A
10.3 Restrictive disease	B

170

Question 5

A subject performs three acceptable FVC trials with the following results.

Parameter	Trial 1	Trial 2	Trial 3
FVC (L BTPS)	4.25	4.10	4.30
FEV ₁ (L BTPS)	3.05	3.25	3.00

7.1 Which FVC value should be reported?

- a) FVC from trial 1
- b) FVC from trial 2
- c) FVC from trial 3
- d) Mean of the three FVC values

7.2 Which FEV₁ value should be reported?

- a) FEV₁ from trial 1
- b) FEV₁ from trial 2
- c) FEV₁ from trial 3
- d) Mean of the three FEV₁ values

171

Answer

A subject performs three acceptable FVC trials with the following results.

Parameter	Trial 1	Trial 2	Trial 3
FVC (L BTPS)	4.25	4.10	4.30
FEV ₁ (L BTPS)	3.05	3.25	3.00

7.1 Which FVC value should be reported?

- a) FVC from trial 1
- b) FVC from trial 2
- c) **FVC from trial 3**
- d) Mean of the three FVC values

7.2 Which FEV₁ value should be reported?

- a) FEV₁ from trial 1
- b) **FEV₁ from trial 2**
- c) FEV₁ from trial 3
- d) Mean of the three FEV₁ values

172

Post Course Submission

ASSESSMENT



- 10 spirometry tests
- De-identified
- Best three loops to be shown
- Data for best three test
- 1 month to submit unless extension requested

173

Course in Spirometry - Post Course Practical Submission

Student Name: _____
 Date of Birth: _____
 Date of face to face course attendance: _____
 Submission Date: _____

Instructions

All students must submit 10 spirometry assessments conducted following your practical face to face session.

- De-identified spirometry results from a subject you have measured.
 - For each trial attempted, irrespective of whether acceptability and/or repeatability criteria have been met, supply -
 - Graphical presentation of each of the trial performed – volume time and flow volume –
 - Data for all trials attempted (at least FEV₁/ FVC, FVC, FEV₁, PEF₁)
 - Comments about test acceptability and repeatability.
 - Final interpretation of results.
- Following completion please upload to the online portal as indicated or email to spirometry@kinnecttraining.com.au
 - Feedback will be provided for the submission by your Trainer / Assessor.

Please provide the following graphs / tables for each assessment by pasting a screen shot or attaching your information to this document (please make sure it is labelled correctly)
 To add a screen shot please use the Snipping Tool on your computer

Flow Volume Loops Graph (paste screen shot below or attach to document)

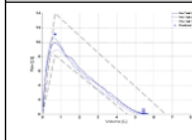

Parameters and Results (paste screen shot below or attach to document)

Parameter	Mean	SD	Min	Max	Units
FEV1	1.2	0.2	0.8	1.6	L
FVC	2.5	0.3	2.0	3.0	L
PEF1	1.5	0.2	1.2	1.8	L/s
Flow	1.5	0.2	1.2	1.8	L/s
Volume	2.5	0.3	2.0	3.0	L

174

PCS Example 1– Test quality A, but FEV1 taken from loop with submaximal expiration

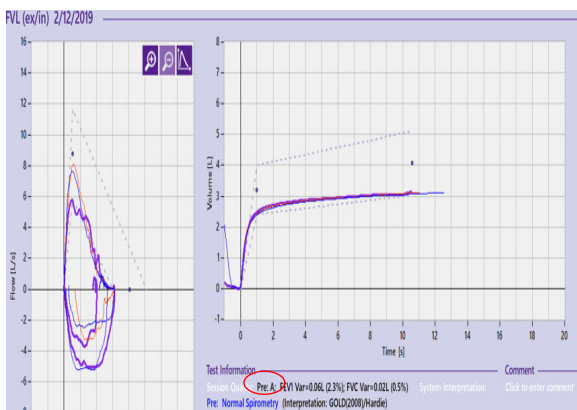

		Pre					
Trial Rank	Pred	LLN	Best	%Pred	Trial 1	Trial 2	Trial 3
Time					7:39:55 AM	7:42:58 AM	7:44:37 AM
FVC [L]	4.06	3.03	3.13	77	3.13	3.12	3.10
FEV1 [L]	3.19	2.39	2.48	78	2.48	2.42	2.39
FEV1/FVC	0.800	0.722	0.791	99	0.791	0.777	0.771
FEF25-75 [L/s]	3.21	2.12	2.52	79	2.52	2.09	2.02
PFF11 [L/s]	8.75	5.85	8.09	92	5.82	8.09	7.65

175

What's wrong with this submission?

Flow [L/s] vs Volume [L] and Volume [L] vs Time [s] plots. Test Information: Pre: B, FEV1 Var=0.11L (3.2%), FVC Var=0.04L (0.9%).

End of test criteria not met (Plateau criteria)

		Pre						
Trial Rank	Pred	LLN	Best	%Pred	Trial 1	Trial 2	Trial 3	Trial 4
Time					4:16:10 PM	4:16:45 PM	4:17:29 PM	4:18:13 PM
FVC [L]	3.65	2.92	4.30	118	3.05	4.30	4.38	4.26
FEV1 [L]	3.07	2.46	3.54	115	3.04	3.42	3.48	3.54
FEV1/FVC	0.845	0.730	0.823	97	0.996	0.797	0.794	0.830
FEF25-75 [L/s]	3.41	2.18	3.90	114	5.12	3.43	3.46	3.90

Add Trial, Add Post

176

Patient Information

Name: [REDACTED]
 ID: #0054
 Age: 23 (30/09/1997)
 Height: 183 cm
 Weight: 153 kg BMI: 45.7
 Gender: Male
 Ethnicity: Caucasian
 Smoker: No

Test Information

Test Type: [REDACTED]
 Test Date: [REDACTED]
 Post Time: [REDACTED]
 Interpretation: Predicted
 Value Selection: BTPS (IN/EX)

Test Result

Your FEV1 / Predicted: 80%

Parameter	Pred	LLN	Pre			Trial 3	%Pred
			Best	Trial 2	Trial 1		
FVC [L]	5.93	4.90	4.87*	4.87*	4.85*	4.60*	82
FEV1 [L]	4.99	4.19	3.97*	3.97*	3.89*	3.65*	80
FEV1/FVC	0.848	0.770	0.816	0.816	0.803	0.793	96
FEF25-75% [L/s]	5.00	4.82	4.15*	4.15*	3.76*	3.47*	83
PEF [L/s]	11.49	8.59	8.87	8.87	8.77	8.83	77
FET [s]	-	-	7.9	7.9	8.6	11.0	-
FIVC [L]	5.93	4.90	5.38	5.38	5.28	5.24	91
PIF [L/s]	-	-	9.02	7.40	9.02	7.57	-

Session Quality: Pre A (FEV1 Var=0.08L (2.0%); FVC Var=0.02L (0.3%))
 System Interpretation: Pre Restriction probable; further examination recommended

Has this patient true restriction?

177

Please evaluate this session to help us improve.
 Your feedback is important!

178